



Funded by
the European Union

Horizon Europe

EUROPEAN COMMISSION

European Climate, Infrastructure and Environment Executive Agency (CINEA)

Grant agreement no. 101136131



SHIFT to Direct Current

Deliverable D1.1

DC Applications, Challenges, Opportunities and Evolution Scenarios

Document Details

Due date	31-03-2024
Actual delivery date	31-03-2024
Lead Contractor	EDP NEW
Version	1.0
Prepared by	Carlos Cardoso, Motaz Ayiad (EDP NEW); Holger Krings, Rainer Durth (PHOENIX CONTACT); Kilian Drexler (FRAUNHOFER); Ahmad Makkieh, Jean-Francois Leger (Schneider Electric); Lina Ruiz, Nicolas Rousselet (Nexans); Katharina Hetzenecker (RWTH); Oleksij Chumak (EATON); Samy El Kamch (Watt & Well); Andrii Chub (TalTech); Hugo Morais, Guilherme Paraíso; Pedro Costa (INESC ID); César Augusto Slongo, Sarah Nasr (EDF); Lucas Pereira (ITI, LARSyS, Instituto Superior Técnico); Carlos Castro (APRAM); Andrea Colavitto (FICANTIERI SI)
Reviewed by	Dimitrios Baros (EATON); Salvador Ceballos (Tecnalia)
Dissemination Level	Public

Project Contractual Details

Project Title	Shift to Direct Current
Project Acronym	SHIFT2DC
Grant Agreement No.	101136131
Project Start Date	01-12-2023
Project End Date	31-05-2027
Duration	42 months

Document History

Version	Date	Contributor(s)	Description
0.1	05-02-2024	EDP NEW, INESC-ID	Table of Contents
0.3	12-03-2024	EDP NEW, PHOENIX, FRAUNHOFER, SCHNEIDER, NEXANS, RWTH, EDF, TalTech, W&W, IST-ID, INESC-ID, APRAM, FICANTIERI SI	Internal draft
0.4	21-03-2024	EATON, TECNALIA	Internal review
1.0	26-03-2024	EDP NEW	Final version

Disclaimer

This document has been produced in the context of the SHIFT2DC project. Views and opinions expressed in this document are however those of the authors only and do not necessarily reflect those of the European Union or the European Climate, Infrastructure and Environment Executive Agency (CINEA). Neither the European Union nor the granting authority can be held responsible for them.

Acknowledgment

This document is a deliverable of SHIFT2DC project. SHIFT2DC has received funding from the European Union's Horizon Europe programme under grant agreement no. 101136131.



**Funded by
the European Union**

Executive Summary

Deliverable D1.1 – “DC Applications, Challenges, Opportunities and Evolution Scenarios” of the SHIFT2DC project, aims at presenting a first vision of the partners concerning the existing Direct Current (DC) technology applications, the main challenges and opportunities, and the expected evolution scenarios.

This document analyses the results of the existing works and map the main technical barriers and opportunities of Medium Voltage Direct Current (MVDC) and Low Voltage Direct Current (LVDC), contributing to objective B4 “Analysis and identification of the main barriers (technical and non-technical) for the development and deployment of MVDC and LVDC systems” of the Project SHIFT2DC.

The DC applications that are analysed in this document are divided between Industry, Ports, Data Centres, Buildings and Grids. For each type of application, the main equipment that can benefit from DC integration are described, as well as the rationale of DC usage instead of Alternating Current (AC), and the basis for some use cases, such as Renewable Energy Source (RES) generation integration, Electric Vehicle (EV), hosting capacity and efficiency, among others.

The main challenges of DC technology implementation are also described, namely Technical/Technological, Economical, Regulatory, Standardization, Stakeholder Acceptance and Ecosystems. The “Economical, Regulatory and Standardization” challenges are very specific and will be further analysed in the deliverable D1.2 of this project. Concerning the technical challenges, they are the focus of this document, with the protections, operation and control, and some equipment being identified as the main challenges.

In the next and final section, the authors delve into presenting the opportunities and possible evolution scenarios of DC tech, for each one of the applications that were initially described. The main opportunities range from increases in efficiency, controllability, resiliency, and sustainability applied to all the discussed applications. Technology proposed evolution scenarios are also studied, and roadmaps, where available, are also presented, focusing of coupling the advantages of the adoption of DC with European Union (EU) climate, efficiency, and resiliency goals.

Table of Contents

Executive Summary	4
Table of Contents	5
List of Figures	7
List of Tables.....	8
Acronym	9
1 Introduction	12
1.1 Scope and Objectives	12
1.2 Structure.....	13
1.3 Relationship with other deliverables	13
2 DC Applications	14
2.1 Industry	14
2.2 Ports	15
2.2.1 Shore-Side Electricity (SSE)	15
2.2.2 Integration of Renewable Energy Sources and Battery Energy Storage Systems	16
2.2.3 Electrification of cranes and cargo handling.....	16
2.2.4 Participation in Flexibility Services.....	16
2.2.5 Ports as Microgrid.....	17
2.2.6 Ports as Multi-Energy Hubs	17
2.3 Data Centres.....	18
2.4 Buildings	20
2.4.1 Renewable energy integration.....	21
2.4.2 Lighting and climatization.....	22
2.4.3 Electric Mobility.....	22
2.4.4 Electronic equipment	22
2.4.5 Building Supervision	23
2.5 MVDC and LVDC Grids	23
2.5.1 Grid Architecture	23
2.5.2 MVDC Grids	24
2.5.3 LVDC Grids	25
3 DC Challenges.....	26
3.1 Technological.....	26
3.1.1 Grid topology and earthing.....	26
3.1.2 Corrosion risk under DC distribution	27
3.1.3 Earthing systems.....	27
3.1.4 Protection.....	29
3.1.5 Cables	31
3.1.6 System operation and control	31
3.1.7 Power electronics converters	32
3.2 Economical, Regulatory and Standardization	34
3.3 DC Eco-Systems	38
3.3.1 The challenge of distribution grids	38
3.3.2 Countries already facing capacity challenges	39
3.3.3 Our daily lives are all around DC sources and DC loads	39
3.3.4 Addressing Resilience through Control Standardization.....	40
3.3.5 Cyber issues and concerns	40
3.3.6 Advancing Global Adoption within the eco-system	40
3.4 Stakeholder Acceptance.....	41
4 DC Opportunities and Evolution Scenarios.....	43

4.1	Industry	43
4.2	Ports	44
4.3	Data Centres	46
4.4	Buildings	48
4.4.1	Efficiency	48
4.4.2	Controllability	49
4.4.3	Resiliency	49
4.4.4	Perspectives	50
4.5	MVDC and LVDC Grids	51
4.5.1	MVDC Grids	51
4.5.2	LVDC Grids	52
4.5.3	Cables	53
5	Conclusions	55
5.1	Summary	55
5.2	Progress	56
5.3	Main Challenges	56
5.4	Next deliverables	56
6	References	57

List of Figures

Figure 2-1: Possible DC microgrid implementation in a port	17
Figure 2-2: Power conversion stages in a standard IT powertrain with a centralized AC UPS	19
Figure 2-3: DC based data centre power architecture	20
Figure 2-4: Classic structure of a building operating with an LVDC grid	21
Figure 2-5: Schematic of MVDC system [34].....	24
Figure 2-6: A conceptual example of an MVDC grid [34].	24
Figure 2-7: A conceptual example of an LVDC grid [34].	25
Figure 3-1: Electrochemical Corrosion Phenomena illustration	27
Figure 3-2: DC TT Earthing Configuration	28
Figure 3-3: DC TN-C Earthing Configuration.....	28
Figure 3-4: DC TN-S Earthing Configuration.....	29
Figure 3-5: DC IT Earthing Configuration	29
Figure 3-6: Solid state (left) and hybrid (right) circuit breaker designs [38]	30
Figure 3-7: Grid availability for new load (left) and feed-in (right) for users above 3*80 A [49].	39
Figure 4-1: Data centre power architecture with a Rack-level DC-distribution	47
Figure 4-2: decentralized control principle of LVDC distribution grid [87].	49
Figure 4-3: Example of bipolar configuration in LVDC distribution grid [87].	49
Figure 4-4: future ring/meshed LVDC distribution cluster [87].	50
Figure 4-5: Project TIGON vision for MVDC and LVDC distribution deployment [90].	52
Figure 4-6: LVDC technology roadmap [89].	53

List of Tables

Table 2-1: Typical PUE values for different types of data centres	18
Table 3-1: Brief synthesis of DC applicable standards	35
Table 4-1: Efficiency analysis of LVDC buildings	48

Acronym

AC	Alternating Current
AI	Artificial Intelligence
AMP	Alternative Maritime Power
BESS	Battery Energy Storage System
BMS	Battery Management System
CABEE	China Association for Building Energy Efficiency
CAPEX	Capital Expenditure
CAT	Consumer Acceptance of Technology
CENELEC	European Committee for Electrotechnical Standardization
CI	Cold Ironing
CIGRE	Conseil International des Grands Réseaux Électriques in French
CO ₂	Carbon Dioxide
DAGCT	Diode-Assisted Gate Commutated Thyristor
DC	Direct Current
DER	Distributed Energy Resources
DSO	Distribution System Operator
EE	Expert Elicitation
EES	Electrical Energy Storage
EMC	Electromagnetic Compatibility
EMI	Electromagnetic Interference
EMS	Energy Management System
EMSA	European Maritime Safety Agency
ENTSO	European Network of Transmission System Operators for Electricity
ESS	Energy Storage System
ETSI	European Telecommunications Standards Institute
EU	European Union
EV	Electric Vehicle
FACTS	Flexible Alternate Current Transmission Systems
FC	Fuel Cell
FEN	Flexible Electrical Networks
FS	Future Studies
GaN	Gallium Nitride
GHG	Greenhouse Gas
H2020	Horizon 2020
HCB	Hybrid Circuit Breaker
HF	Halogen Free
HMI	Human-Machine Interface
HV	High Voltage
HVAC	Heating, Ventilation, and Air Conditioning
HVDC	High Voltage Direct Current
IBR	Inverter-Based Resources
ICT	Information and Communication Technologies
IEEE	Institute of Electrical and Electronics Engineers

IEC	International Electrotechnical Commission
IMO	International Maritime Organization
IP	Intellectual Property
IoT	Internet of Things
IT	Information Technology
IT	Isolated Terra (in section 3.1.1)
KPI	Key Performance Indicator
LCC	Line-Commutated Converters
LED	Light Emitting Diode
LV	Low Voltage
LVAC	Low Voltage Alternating Current
LVDC	Low Voltage Direct Current
MOSFET	Metal–Oxide–Semiconductor Field-Effect Transistor
MV	Medium Voltage
MVAC	Medium Voltage Alternating Current
MVDC	Medium Voltage Direct Current
OLED	Organic Light Emitting Diode
ODCA	Open DC Alliance
OPEX	Operational Expenditure
OPS	Onshore Power Supply
P2G	Pole-to-Ground
P2P	Pole-to-Pole
PE	Protective Earthing
PEM	Protective Earthing Mid-point
PO	PolyOlefin
PoE	Power over Ethernet
PSU	Power Supply Unit
PUE	Power Usage Effectiveness
PV	PhotoVoltaic
PVC	PolyVinyl Chloride
R&D	Research and Development
RES	Renewable Energy Source
S2G	Ship-to-Grid
SCADA	Supervisory Control and Data Acquisition
SiC	Silicon Carbide
SKU	Stock Keeping Unit
SPD	Surge Protective Devices
SSCB	Solid-State Circuit Breaker
SSE	Shore-Side Electricity
SSP	Shore-to-Ship Power
TAM	Technology Acceptance Model
TEN-T	Trans-European Transport Network
THD	Total Harmonic Distortion
TN-C	Terra-Neutral Combined
TN-C-S	Terra-Neutral Combined-Separated
TN-S	Terra-Neutral Separated
TPE	ThermoPlastic Elastomer

TRL	Technology Readiness Level
TT	Terra-Terra (TT)
UPS	Uninterruptible Power Supply
USB	Universal Serial Bus
UTAUT	Unified Theory of Acceptance and Use of Technology
V2G	Vehicle-to-Grid
VARC	Voltage-source-converter Assisted Resonant Current
VSC	Voltage Source Converters
WAMPAC	Wide Area Monitoring Protection and Control
WP	Work Package

1 Introduction

1.1 Scope and Objectives

This document discusses the modern emerging Direct Current (DC) technologies and solutions. DC has emerged as a significant alternative in modern energy systems, offering diverse applications while also presenting unique challenges and promising opportunities for further evolution. From renewable energy integration to data centres and electric vehicles, the domain of DC spans various sectors, each with its own set of demands and potential for growth.

The history of DC grids can be traced back to the pioneering efforts of Thomas Edison in the late 19th century, when he established the first commercial electric power distribution system using DC [1]. Initially, DC grids found success in urban areas, providing electricity for lighting and early industrial applications. However, inherent limitations such as voltage drop over long distances and the lack of efficient voltage conversion methods hindered widespread adoption for large-scale power distribution. In contrast, AC's ability to efficiently step up and down voltage levels using transformers, coupled with its capability for long-distance transmission, led to its dominance in power systems globally.

The emergence of solid-state power electronics and advancements in High Voltage Direct Current (HVDC) technology sparked renewed interest in DC grids for long-distance transmission and interconnection of power systems [2]. Presently, DC grids play a critical role in modern energy infrastructure, facilitating the integration of Renewable Energy Sources (RES), enhancing grid stability, and enabling efficient transmission over vast distances. Ongoing research and development are continuously expanding the capabilities and applications of DC grids, shaping the future landscape of electric power distribution.

Considering the recent breakthroughs in DC technology, this deliverable will prioritize the following topics:

- **Understanding Diverse DC Applications:** The primary objective is to comprehensively understand the breadth and depth of DC applications across different sectors, including renewable energy integration, data centres, electric vehicles, industry, ports and residential/commercial buildings. This involves analysing the specific requirements, challenges, and opportunities associated with each application area.
- **Identifying Challenges:** Another key objective is to identify the challenges hindering the widespread adoption of DC technology while simultaneously uncovering the opportunities it presents for innovation and growth. This entails examining issues such as standardization, grid integration, cost barriers, and safety concerns, as well as exploring potential areas for advancements and market expansion.
- **Promoting Collaboration and Standardization:** Facilitating collaboration among stakeholders and promoting standardization efforts is also a key objective. By fostering cooperation between industry players, research institutions, policymakers, and standards organizations, the aim is to accelerate innovation, streamline interoperability, and drive market growth. Standardization efforts play a pivotal role in ensuring the compatibility, reliability, and scalability of DC systems across different applications.

- **Identifying Opportunities and Proposing Evolution Scenarios:** A crucial aspect of the scope is to propose evolution scenarios that outline potential pathways for the future development of DC applications. These scenarios envision how DC technology could evolve in response to technological advancements, market dynamics, regulatory changes, and societal trends. They provide a strategic framework for stakeholders to navigate the evolving landscape of DC technology and infrastructure.
- **Encouraging Research and Development:** Lastly, it is important to keep fostering research and development initiatives to advance the state-of-the-art in DC technology. This involves supporting Research & Development (R&D) efforts focused on improving system efficiency, enhancing grid integration capabilities, developing novel applications, and addressing emerging challenges. By investing in innovation and knowledge creation, the goal is to unlock new possibilities and drive continuous improvement in DC applications.

In summary, the scope objectives of DC applications encompass a comprehensive exploration of its diverse applications, identification of challenges and opportunities, proposition of evolution scenarios, promotion of collaboration and standardization, and encouragement of research and development. These objectives collectively aim to catalyse progress and innovation in the field of DC technology, paving the way for its widespread adoption and impact across various sectors.

1.2 Structure

The document comprises six chapters, with Chapter 1 serving as the introduction and outlining the deliverable objectives. In Chapter 2, the focus is on exploring DC applications across various systems, from industry to power grids. Chapter 3 delves into the discussion and exposition of challenges encountered in DC applications. Moving forward, Chapter 4 converts these challenges into opportunities for research and analysis to be explored and studied, as well as offering evolution scenarios for DC applications, envisioning potential pathways for future development. Finally, Chapter 5 concludes the deliverable by summarizing the main findings and providing a comprehensive overview of the document's content.

1.3 Relationship with other deliverables

This deliverable D1.1 is the first one in this project, from the first Task in the first Work Package (WP). It lays the foundations and state of the art before SHIFT2DC and serves as a baseline and perspectives to take in account in this project.

The results of this task, and thus this deliverable, will be used in Task 1.2 for the identification of the main policies and regulatory frameworks and in Task 1.3 – DC applications Use Cases. They will also contribute to the WP2 (WP2 – DC Solutions Integrations: Tools, methods and applications) and WP3 (DC Solutions: Assets, Devices and appliances) in the development of new solutions.

2 DC Applications

This section of is devoted to present technical knowledge and details about existing applications of Direct Current technology. The chapter is divided by the type of application that will be addressed in SHIFT2DC project. These are the four types of applications that this project is devoted to (Industry, Ports, Data Centres and Buildings), as well as Grids application which is transversal to the other ones. This chapter lays the foundation for the project to delve in these innovative applications, and for the next sections of the document.

2.1 Industry

Industrial production plants often have motorized drives. For reasons of efficiency, many of these historically AC-based drives have been equipped with upstream frequency converters. Although these are still connected to the AC grid, the DC intermediate circuit of an inverter offers excellent opportunities to be connected to a DC grid.

The increasing penetration of robot-controlled drives typically include inverter-based drives on board anyway. The potential recuperation power produced during breaking of robots' motors could be exploited and be harvested into a DC grid, instead of being wasted in resistors and converted into heat, as it typically happens in conventional AC grids.

Industrial plants are also characterized to a large extent and increasingly by automated processes. These automation components are already based on 24 V DC, which means that connecting them to a DC grid which means that connecting them to a DC grid will not be an issue in any case. This is valid for any Information Technology (IT) component as well. In addition, network technology is now very promising, since it can provide DC power to sensors and actuators via Power over Ethernet (PoE) technology.

Special industrial processes such as electroplating systems for galvanizing non-precious metals or painting lines are also direct DC consumers. There are now hardly any compelling reasons why industrial systems should be based on an AC grid. Of central importance is the availability and breadth of the range of components for the infrastructure, such as circuit breakers etc., which are currently available in much greater variety and quantity for AC power grids.

In addition to individual industrial applications, production halls have already been completely or largely built or converted to DC as part of research projects, in order to validate the expected benefits in practice. For example, the first industrial buildings with DC grids have already been set up for testing.

Schaltbau GmbH's "Next Factory" is currently evaluating the extent to which the advantages of DC grids can be proved in an industrial environment. Initial findings are very promising [3].

Another example of an industrial process is a body shop at the BMW Group plant in Dingolfing, which is based on a DC supply. It is expected that around 20% of the energy can be saved in this way [4].

While industrial processes can also be perfectly supplied by DC grids, it should not be forgotten that an essential part of industrial complexes is also the building infrastructure, which often involves extensive Heating, Ventilation, and Air Conditioning (HVAC) systems, sometimes even placing very high demands on climatic conditions, e.g. in the production of semiconductors or the manufacturing of electronic assemblies, but also in the use of plastics, e.g. in the field of injection moulding. Often exact temperatures and humidity are required to guarantee high quality in the resulting products.

Buildings and their infrastructure therefore often account for a significant proportion of energy requirements. Here, too, the advantages in the area of building infrastructures for use in lighting, IT, HVAC etc. applications are easy to understand.

This often includes applications such as the integration of photovoltaic systems, often in combination with battery storage systems and increasingly also DC charging infrastructure on the factory premises for charging vehicles in intralogistics traffic or on pool vehicles in the fleet. These will be presented in detail in Section 2.4.

2.2 Ports

In the European Union, in 2021, maritime transport was responsible for the emission of 124.3 million tonnes of CO₂ [5]. In July 2023, the International Maritime Organization (IMO) defined new targets for reducing greenhouse gas (GHG) emissions in maritime transportation, formulating, and adopting a set of measures by 2025 to achieve these reduction targets [6]. According to the FuelEU Maritime regulation [7], in 2030, container and passenger ships (including cruise ships) with a gross tonnage equal to, or exceeding 5,000, must utilize shore power connections when docked at major EU ports designated within the trans-European transport network (TEN-T) [8].

The use of DC distribution grid solutions in ports can bring several advantages to improve both flexibility and energy efficiency. There are numerous applications in ports where DC systems can offer various advantages. The following subsections describe some of the most important applications.

2.2.1 Shore-Side Electricity (SSE)

Shore-Side Electricity (SSE), also known as Cold ironing (CI), shore connection, shore-to-ship power (SSP), onshore power supply (OPS) or alternative maritime power (AMP), refers to the practice of supplying shoreside electrical power to a ship while it is docked at berth, allowing its main and auxiliary engines to be turned off, avoiding noise, vibrations and GHG emissions [9]. This enables the ship to maintain continuous electrical power for essential functions such as emergency equipment, refrigeration, cooling, heating, lighting, and other onboard systems while cargo is being loaded or unloaded [10].

According to [11], most of the ships operate at 60 Hz. Considering that the European power grid operates at 50 Hz an important challenge can be identified. A potential approach to mitigate this problem involves the utilisation of a dual busbar system accommodating both 50 Hz and 60 Hz frequencies, allowing ships to connect to the most compatible option. However, reliance solely on a single converter generating power at 60 Hz introduces a vulnerability wherein failure of this converter impacts all ships connected to it. Alternatively, equipping each vessel at berth with an individual converter is another solution that can improve the reliability of the overall system. In this setup, the shore infrastructure comprises an AC-to-DC converter followed by a DC-to-AC converter stage, that generates the 60Hz frequency required for the ship.

Adopting a DC distribution power system in a port with CI can eliminate the first stage of conversion, therefore reducing the number of conversion stages, leading to improved overall energy efficiency. Furthermore, many ships are all-electric and/or are equipped with batteries that require recharge [12] [13]. With a DC busbar, ships can be connected to the shore using simpler DC-DC converters with higher power density.

Another difficulty that should be addressed in implementing CI in ports is the lack of voltage standardisation [14]. Nowadays, the CI system can be connected to the shore using voltages ranging from 380V to 11kV [11]. A DC connection can facilitate the linking of various frequency and voltage levels without the need for conventional AC-AC transformers. Moreover, cable losses are minimized,

and given the substantial power consumption of ships and cruises, energy consumption is bound to decrease.

2.2.2 Integration of Renewable Energy Sources and Battery Energy Storage Systems

Achieving zero carbon footprint in ports encourages incorporating RES, such as PV systems, Fuel Cells (FCs), and wind turbines, into the port's power system. As most of these RES do not guarantee constant power, Battery Energy Storage Systems (BESS) are essential to mitigate the intermittency and variability inherent in many RES, ensuring a reliable and stable power supply. Several ports in Europe, including Belgium (Antwerp), Netherlands (Rotterdam, Amsterdam), Germany (Hamburg), Sweden (Gothenburg), are investing in RES to reduce their carbon footprint and solve their supply problems, as part of efforts to combat climate change [11], [15].

In the context of greener ports, DC distribution systems are considered a smart choice to ensure the port's sustainability and increase energy efficiency. PV and FCs, which inherently produce DC power, stand to benefit from DC integration, avoiding the need for an AC conversion stage. By eliminating the inverter stage, the number of converter stages is reduced, resulting in a more efficient conversion process. Furthermore, issues such as frequency synchronization and reactive power control are non-existent in DC grids. Offshore wind turbines often utilize HVDC for power transmission to shore due to lower losses and reduced cable costs. Implementing DC distribution systems in ports holds promise for efficiently interconnecting offshore wind farms with shore infrastructure, effectively serving as an Energy Hub [16]. Coordinating RES, BESS, and CI will also help to mitigate the impact and variability of power demand on the main system. This aspect is particularly crucial when ships are connected and require high levels of energy and power.

2.2.3 Electrification of cranes and cargo handling

Cranes, hoists, and ground vehicles are used for handling cargo within ports and harbours. To promote the development of more environmentally friendly ports, it is crucial to retrofit these units to run on electricity instead of fossil fuel [17]. Many of these cranes are often equipped with DC motors [18], which, in the case of a DC distribution power system, can be easier connected to the grid without the need for additional conversion stages. Cranes that employ AC motors, when connected to an AC grid, require a rectifier stage followed by an inverter that is able to adjust the frequency and the voltage fed into the motor (variable speed drives). With a DC power system installed in a port, only the inverter stage is required to connect these types of cranes to the grid, which means reduced number of conversion stages and consequently reduced weight, volume, and cost of these equipment. Moreover, most of these cranes are equipped with their own lighting system, which runs on DC power. They can be easily and more efficiently connected to a DC bus rather than an AC bus.

Recent studies focusing on electrical crane technology have demonstrated an interest in integrating BESS into crane operations [19], [20]. These systems are specifically designed to capture and convert the potential energy generated during the lowering and lifting activities of cranes into electrical energy. One notable approach being explored involves utilizing a DC bus and an AC/DC converter as a way of integrating this technology and BESSs.

2.2.4 Participation in Flexibility Services

An interesting and challenging characteristic of Ports is the dynamic behaviour of the consumption imposed by the connection/disconnection of ships [21]. Afterwards, concept of ship-to-grid (S2G) was proposed increasing the potential of Ports in providing services to the system operators [22]. In this regard, several services can be identified that will significantly increase the interest of the electrification

of Ports. As an example, [23] identifies some ancillary services and demand response programs that can be interesting to Ports. Nevertheless, a deep analysis and studies are required in this point to understand and quantify the positive impact of these services in the global port management.

2.2.5 Ports as Microgrid

Ports and microgrids are becoming increasingly intertwined as ports seek to enhance their resilience, sustainability, and energy independence. Electrical grids are susceptible to a wide range of disruptions, including natural disasters like hurricanes, earthquakes, floods, and wildfires as well as the breakdown of aging equipment and outdated infrastructure [24]. These factors pose a significant risk to the reliability and resilience of the grid.

Microgrids, especially DC microgrids, can be a promising solution for decentralized distribution power system in ports, offering a greater flexibility in integrating RES, BESSs, SSE technologies [25]. This enables ports to achieve their own energy independence, assuming control of their energy supply and ensuring continuous operations during grid outages thus reducing economic costs associated with these disruptions. Figure 2-1 shows the structure of a DC microgrid implemented in a port.

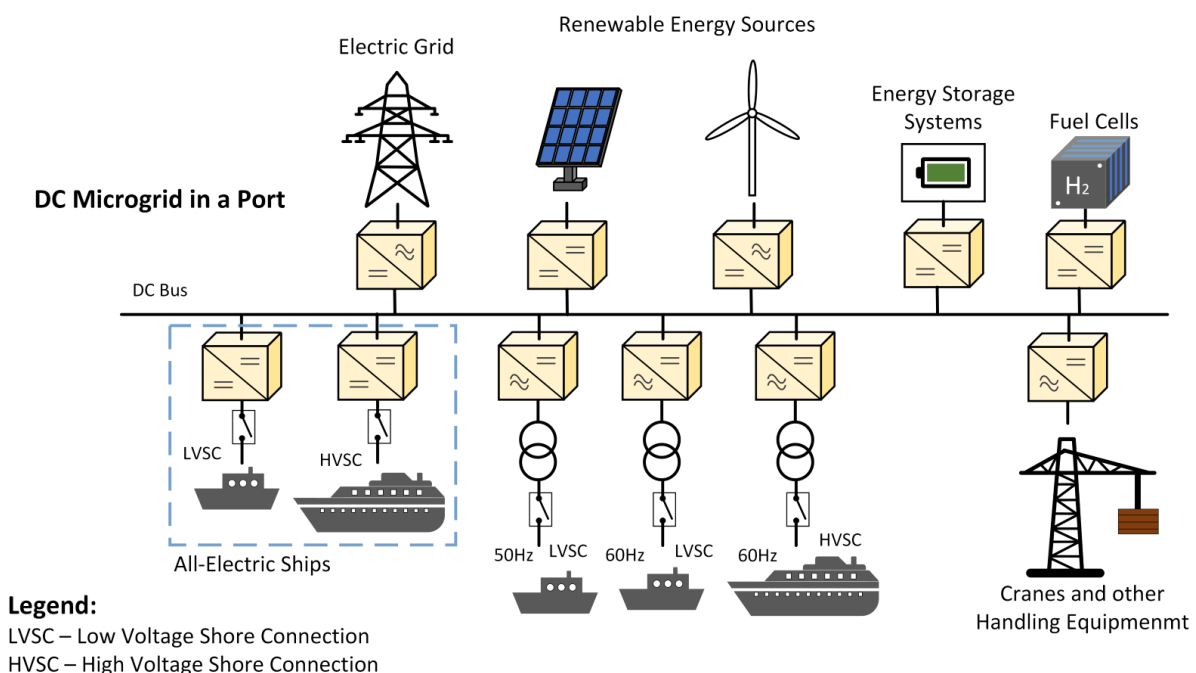

Figure 2-1: Possible DC microgrid implementation in a port

2.2.6 Ports as Multi-Energy Hubs

A more advanced vision is the vision of ports as multi-energy hubs. Energy hubs can play a crucial role in the transition to a more sustainable and resilient energy system. They are uniquely positioned to integrate multiple forms of energy sources such as RES, natural gas, thermal energy, and new alternative fuels like hydrogen [26]. Considering this vision, ports present a very high potential to assume a role of energy hub.

As an example, it is expected that hydrogen powered FCs will be a promising fuel alternative for ships and port vehicles as well as a storage solution when RES exceed their energy demand [27]. As previously mentioned, when combined, FCs and DC distribution systems can offer several benefits

given that it's easier to integrate and operate these types of storage technologies more efficiently in a DC bus.

2.3 Data Centres

The energy consumption of data centres in the EU has increased from 53.9 TWh/a to 76.8 TWh/a between 2010 and 2018 accounting in 2.7% of the electricity demand. The power demand is projected to further increase by 21% to 92.6 TWh/a by 2025 compared to 2018 [28].

The main Key Performance Indicator (KPI) for data centre efficiency is the overall Power Usage Effectiveness (PUE), which compares the total energy used by the facility to the energy used by the IT equipment. According to a survey by the Uptime Institute, the average PUE was 1.55 with 2022 [29]. This means for every kW of computing power, an additional 0.55 kW are needed in cooling, distribution and conversion losses and ancillary facility functions. PUE also depends on the type of data centre as depicted in Table 2-1.

Table 2-1: Typical PUE values for different types of data centres

Data Centre Type	Typical PUE
Hyperscale	1.2 – 1.4
Co-location	1.4 – 1.8
Edge	1.6 – 2.0

While hyperscale data centres have significantly improved their PUE in recent years (for example Google achieves a PUE of 1.07 in their Eemshaven data centre), edge data centres face challenges in achieving similar efficiency due to limited scalability. However, edge data centres are a growing market and are expected to account for 10% of server capacity in the EU in 2025 [28].

Traditionally, power distribution in data centres has been done with AC, consistent with available power from the greater electrical grid as well as with the dominant standards, equipment, and practices used throughout facilities of all kinds. Within the distribution path, between the grid connection and where the final load operates, multiple power conversion stages exist. They serve various functions including power quality stability, power outage back-up, voltage stepdown and AC/DC rectification. Figure 2-2 illustrates a typical AC data centre powertrain with an Uninterruptible Power Supply (UPS), excluding an UPS maintenance bypass. Depending on the availability class (EN 50600, BITKOM category), for a mission-critical facility multiple infeed and a redundant pathway are required (usually in a $n+n$ configuration) which are also not displayed.

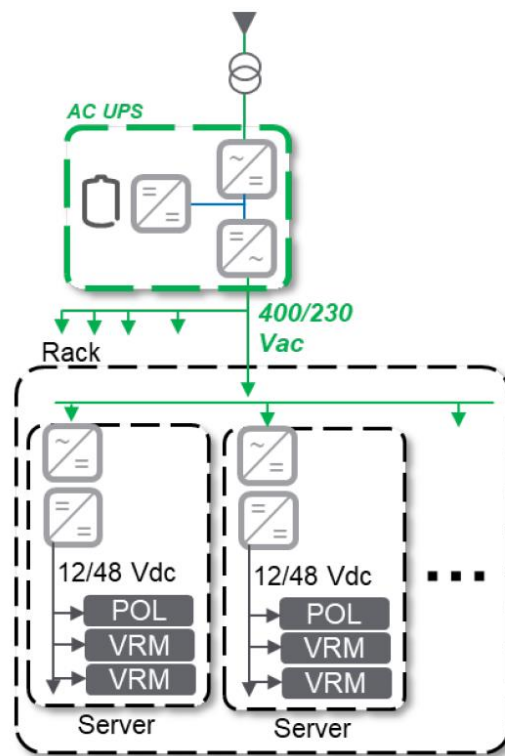

Figure 2-2: Power conversion stages in a standard IT powertrain with a centralized AC UPS

Principal to data centre power architecture and design is the support of critical loads, which must be provided with uninterrupted and high-quality power, otherwise there is a high risk of a service outage. As a result, prominent in traditional architectures and shown in Figure 2-2 is an UPS. While many variations exist, UPSs generally use double conversion topologies with conversion from AC to DC and then conversion back to AC for distribution to the loads. Double conversion UPS systems provide two functions. First, through double conversion, the output is decoupled from the input power, providing pure sine wave output. Second, conversion through DC allows for the integration of DC energy storage which provides uninterrupted power to the loads in the event of loss of upstream power. Energy storage in the UPS is generally, but not exclusively, used to cover gaps in input power during the transition to and from onsite generators.

Simplification is often at the root of efforts to make improvements in systems. In power architectures, minimizing power conversion stages is frequently associated with an increase in efficiency and a decrease in Capital Expenditure (CAPEX) and is often high-lighted by proponents as an advantage of the emerging DC-based architectures in data centres. Given that IT loads in data centres ultimately operate on DC and batteries used upstream of the loads to provide uninterruptable power are also DC, using DC power distribution provides an apparent simplification. When deploying batteries using a centralized UPS, using a DC UPS instead of an AC UPS and distributing the power on a DC level within the facility can maintain this simplification, when viewed at this level of abstraction.

As such, illustrated in Figure 2-3 is a DC based power architecture that realizes this simplification. This architecture involves centralized conversion from 350/700 Vdc to 12/48 Vdc, directly connected to the server level, with battery backup at the DC main bus and, as such, showcases the application of DC for data centres.

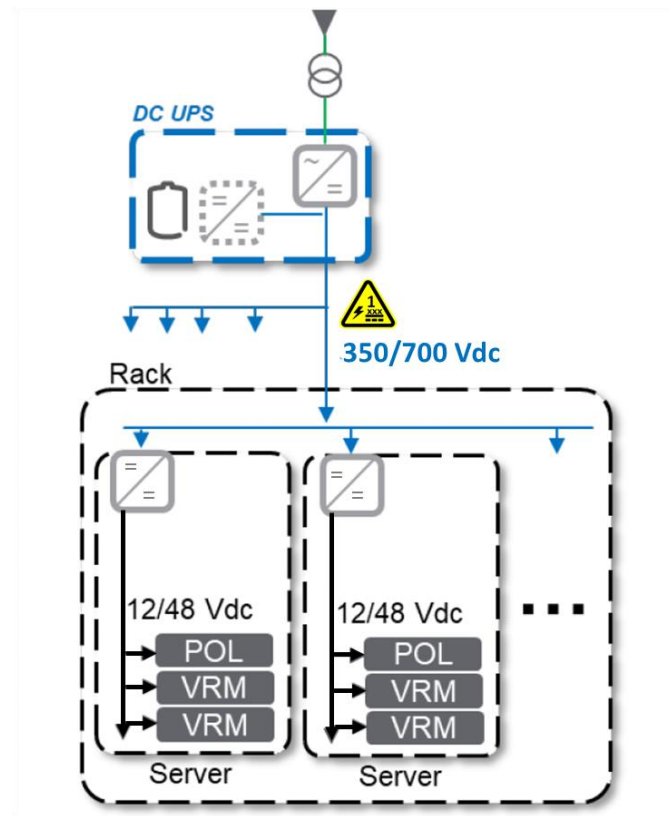

Figure 2-3: DC based data centre power architecture

2.4 Buildings

Nowadays, commercial and industrial buildings are looking to reduce their carbon footprint. The sector is adopting new innovative technologies on different levels: construction materials, heating and cooling systems, renewable power generation, electrical chargers for vehicles, smart management, and other. As EU identified that about 40% of all energy is consumed by buildings, with a similar share in CO₂ emissions. As a result, the Energy Performance of Buildings Directive was introduced in 2010 and revised several times, with last revision accepted in February 2024 as part of the Fit for 55 packages [30]. The directive requires all new building to correspond to zero-emission building requirements, introduces smart readiness indicators, etc. The main drawback of this directive's implementation is in countries defining their individual requirements to building energy labels and associated regulations.

A building that used to be a passive consumer is now a smart local system, similar to a microgrid. It partially produces its own power, stores it, manages its loads in order to reduce its dependency from the main power grid and improve its own resilience. In addition, savings can obviously be made on the total energy bill.

In this context, we notice that most of the equipment in a recent building are DC-native. For example, photovoltaic panels are interfaced through a DC/AC converter because the power is produced in DC. Same applies for EV chargers, batteries, lighting, Universal Serial Bus type-C (USB-C) connected terminals (IT equipment), and appliances including those driven by an inverter such as elevators. A LVDC internal network allows to remove the AC/DC conversion stage at each power load or source. A central mutualized converter with higher efficiency allows to interface the building to the main grid

while prioritizing internal power exchange between the local power source and the loads. A more flexible, resilient and energy efficient building could then be promoted.

The figure below shows an illustration of the main envisaged use-case:

- An interface with the AC utility grid (through AC/DC Interlink converter)
- An internal LVDC distribution system
- DC-based/DC-ready loads
- DC local energy generation (PV, storage, etc.)

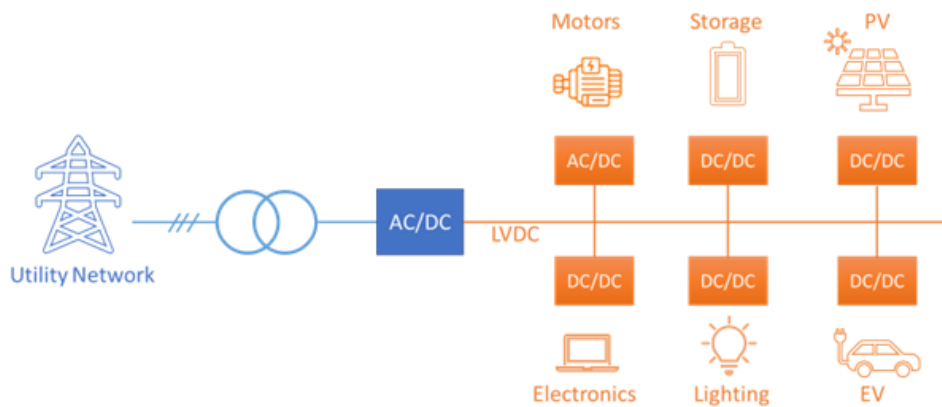

Figure 2-4: Classic structure of a building operating with an LVDC grid

More specifically, the use of LVDC distribution systems for buildings can be advantageous when there is enough local generation from DC-sources and when the energy consumption from DC-based loads is significant. In this perspective, the mutualization of AC/DC and DC/AC conversion steps due to the Interlink converter allows a potential gain in energy efficiency and helps optimizing self-consumption by favouring natural power exchange between assets.

Otherwise, for buildings where there is no local generation or DC-based appliances, the use of DC seems less interesting since energy would be imported from the utility grid, passing through the interlink converter. It would represent potentially an even lower efficiency than classic AC systems.

2.4.1 Renewable energy integration

In buildings, the presence of an LVDC backbone could improve the efficiency associated to PV energy generation and storage systems [31], [32]. Consequently, the presence of these assets in future buildings could be significantly increased, since the technical-economic interest would be higher. In a future perspective where local generation and autonomous operation represent an important feature for sustainable distribution grids, this infrastructure in buildings would represent a crucial LVDC application. Hybrid PV inverters widely adopted in the households represent the first step in this development, but they do not allow to demonstrate all benefits of LVDC technology.

In addition, the use of LVDC as a powerful accelerator for renewable energy integration could help to facilitate the connection of new buildings in already heavily charged distribution grids. Potentially, residential LVDC can improve resilience of residential electricity supply by maximizing self-consumptions and, consequently, mitigating grid congestions, especially in rural areas.

2.4.2 Lighting and climatization

Latest technologies used in lighting and heating are both not only DC-compatible but could also benefit from an increase in operation efficiency if connected directly to a LVDC distribution grid. In this case the input AC/DC converter could be avoided.

In the case of lighting, Light Emitting Diode (LED) and Organic Light Emitting Diode (OLED) technologies are improving exponentially in terms of lifespan, cost and internal efficiency. In new buildings, it is already the most used lighting technology. In addition, for tertiary buildings, lighting represents a considerable share of the total energy consumption of around 15% [33].

For heating/cooling, a LVDC distribution could avoid the AC/DC conversion stage. In fact, the most efficient technologies of heat pumps use variable speed drives, which are composed by a back-to-back AC/DC/AC conversion structure. The creation of a DC bus eliminates the need to use the AC/DC conversion stage of the drive, making it a simpler and more efficient to control variable speed motors. Since the energy consumption associated to climatization is high (around 25% [33]), a gain in energy efficiency could represent considerable energy savings. Electrification of space heating/cooling and water heating targets 80% of energy currently used by buildings, making it single most important application of LVDC in buildings.

2.4.3 Electric Mobility

With the increase in the number of EVs accelerated by considerable decrease in battery prices and energy transition related regulation, buildings present DC-native storage systems which justify a DC distribution in large tertiary buildings, allowing saving money and energy. These batteries can also serve as flexibility levers in the building improving self-consumption and resilience (case of EV with Vehicle-to-Grid (V2G) option).

In addition, direct DC charging (EV connected directly to a common DC bus) is advantageous when synchronized with solar produced power. In this case, EV charging can be implemented directly through photovoltaic panels, especially if the charging power curve matches with PV power generation.

2.4.4 Electronic equipment

Electronic devices increasingly constitute a significant share of building consumption.

They present equipment called “DC ready” and which are supplied with DC by an external AC/DC converter. Here are some examples:

- Phones
- Laptops
- Monitors (example: Alphatronics-12VDC)
- Security devices (fire detectors, cameras, etc.)
- Computer network equipment (routers, servers, etc.)
- Building Management System (BMS)
- etc.

These devices therefore constitute good candidates for a DC network, especially since they are also connected to the data network which can also be used as an energy network (PoE, USB). Note that the power carried by an Ethernet cable (category 5 and above) is limited to 100W (71 watts supplied at 100

meters), hence the possibility of connecting only low-power devices. Powering these devices directly with DC will make it possible to eliminate a conversion stage at the device level, the AC/DC rectifier, and therefore energy efficiency would be enhanced. In fact, the conversion is not eliminated but centralized in a single more efficient converter supplying the DC bus to which these devices will be connected.

In addition, in large tertiary buildings supplied with three-phase power, DC wiring is simplified because it is not necessary to balance the phases.

Finally, the elimination of external power sources (adaptors) will reduce e-waste and therefore environmental impact.

2.4.5 Building Supervision

A Smart building is a connected system comprising loads, sources and control, where data collection is essential to achieve the best performance in terms of efficiency and energy consumption. A better understanding of the different uses within the building contributes to rethink the design of the LVDC cable. LVDC cables (transmitting power and data) as enablers for supervision contribute to the cable becoming a smart and active part in the life of the building.

2.5 MVDC and LVDC Grids

In the previous subsection, we discussed a wide variety of DC applications. However, they all share the common characteristic of presenting demand on the DC side (DC load). In this section, we will explore the concept of using MV and LV DC networks as distribution/grid applications instead of relying on AC distribution/grid.

Medium and low voltage DC systems typically operate at voltages below 30 kV and 1 kV, respectively [34]. MVDC or LVDC networks inherit the efficiency, reliability, and flexibility of DC, which make it an attractive option for powering a variety of applications within these voltage ranges. These applications are presented in the modern power infrastructure as means of integrating renewable power, electrifying transportation, supporting data centres, powering residential and commercial buildings, and facilitating industrial processes. The interconnection between MVDC and LVDC network requires a DC-DC converter, a process is known as voltage stepping down (e.g. 20 kV / 1kV) [35]. Topologies for DC-DC converters vary based on power flow directionality and the need for galvanic isolation.

2.5.1 Grid Architecture

In AC systems, the architecture of MV to LV grids, such as distribution systems, varies depending on the area of supply. The grid architecture can take the form of an open loop, also known as radial operation, and can be tailored to meet specific needs. For instance, in rural areas with lower energy demand, a single feeder is often sufficient to supply power to the entire area. However, that's not always the case for DC systems.

The interchangeability between selecting AC or DC systems on HV grids is already well-established and accepted. However, with the rapid evolution of power electronics technology and the rise of distributed power generation and consumption, MVDC technologies are garnering increasing attention. MVDC serves as the crucial interconnection layer between HV and LV systems, making it essential to establish MVDC grids to facilitate opportunities for integrating LVDC grids with DC loads and balancing voltage levels. The break-even distance between MVAC and MVDC, based on total losses in power lines, ranges from less than 10 km at 10 kV to approximately 30 km at 33 kV [34].

An example schematic in Figure 2-5 shows a modern AC/DC hybrid grid, spanning from HV to LV through MVDC interconnection, illustrates the integration of AC and DC systems to optimize power distribution and meet evolving energy demands.

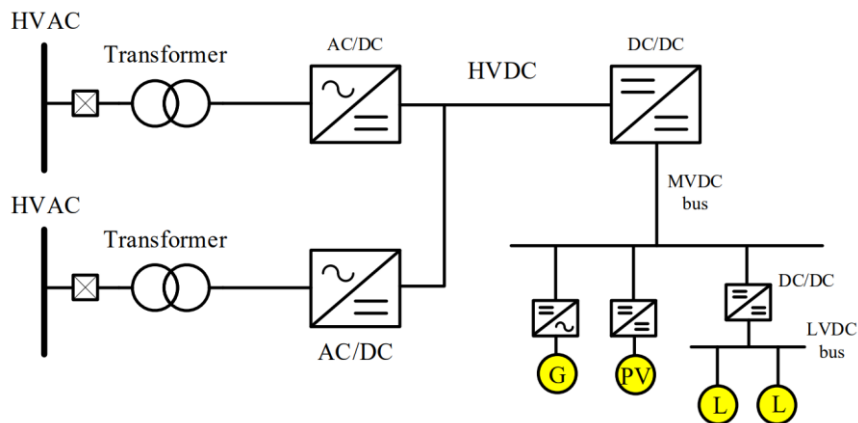

Figure 2-5: Schematic of MVDC system [34].

2.5.2 MVDC Grids

The concept of MVDC is primarily proposed to facilitate the integration of renewable power generation systems, energy storage systems (e.g., batteries), loads (e.g., industrial), and AC utilities. A conceptual architecture is depicted in Figure 2-6, which anticipates fewer voltage conversion stages compared to MVAC systems. However, as this voltage level is still conceptual, further research and investigation must be conducted, particularly regarding system reliability and sustainability under faults, blackouts, and major disturbances [34]. Assessing the robustness of MVDC systems in such scenarios is crucial to ensure their effectiveness and resilience in real-world applications.

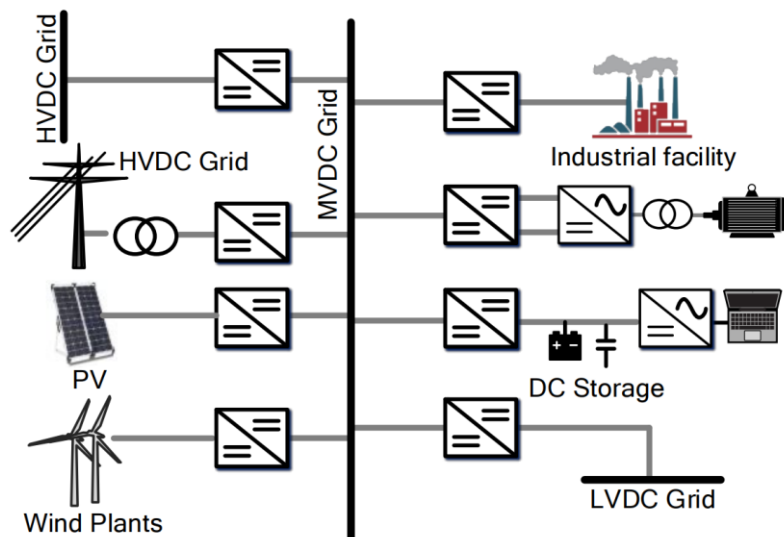

Figure 2-6: A conceptual example of an MVDC grid [34].

2.5.3 LVDC Grids

On the other hand, the LVDC system, which is also still conceptual, is typically presented as a microgrid, often comprising ring networks operating in open (as radial networks) or closed loops as shown in Figure 2-7. Similar to MVDC, LVDC is utilized for coupling distributed generation systems (e.g., photovoltaic arrays), energy storage devices (e.g., batteries), local electric vehicle charging stations, and loads at lower power rating (voltage levels). LVDC is expected to exhibit higher efficiency and simpler power interface compared to AC systems in local distribution systems (e.g., rural power systems, EV charging stations). This simplicity and efficiency make LVDC an attractive option for various applications, particularly in decentralized energy systems where distributed generation and consumption are prevalent [34]. However, like MVDC grids, further research and development are necessary to validate its performance, reliability, and scalability in real-world scenarios.

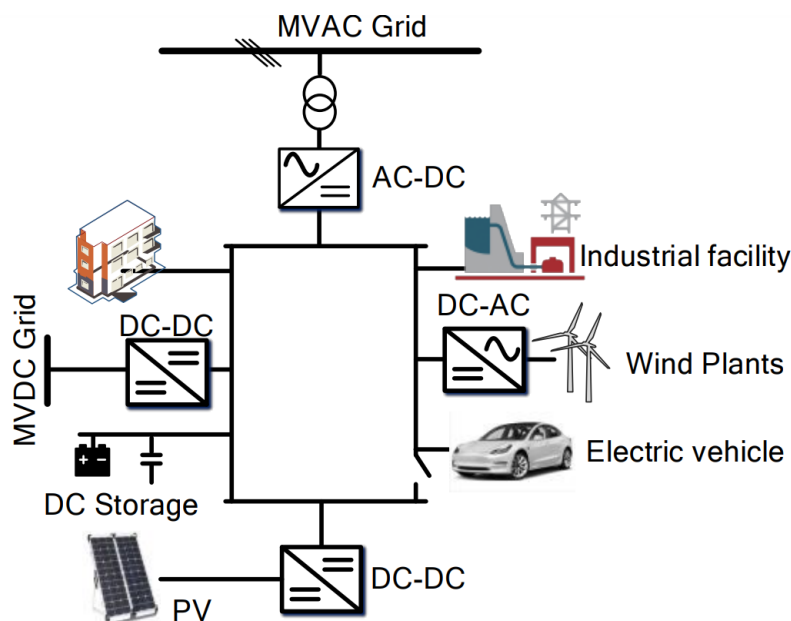

Figure 2-7: A conceptual example of an LVDC grid [34].

3 DC Challenges

Several technical, economical, regulatory and standardization barriers need to be overcome to create favourable conditions for the massive adoption of DC technologies. Also importantly challenging, are the stakeholder acceptance of DC tech and DC eco-systems activities to develop and promote DC.

The SHIFT2DC project is designed to address all these requirements and challenges. In fact, the economical, regulatory and standardization challenges are quite distinct, and will be addressed in a specific project task (T1.2 - Policies, Regulatory framework, and Market Architecture). Thus, just a brief description of these types of challenges will be described in this chapter. On the contrary, Technological Challenges, Acceptance and Eco-systems will be addressed in detail in the following subsections, to provide a first vision for the SHIFT2DC project.

3.1 Technological

DC systems are characterized by prevalence of active components based on power electronics devices, permanent voltage existence, larger capacitance in the power system. All aspects of operation, safety and power system component interoperability fundamentally differs from the AC distribution system. Therefore, with the benefits of innovative approach DC distribution brings new challenges in technological organization of the grids. In the following we will address some of the more prominent ones.

3.1.1 Grid topology and earthing

DC distribution systems present a variety of topologies, such as bus, ring, and network structures. These can be configured with either unipolar or bipolar and are designed to accommodate bidirectional power flows. Such configurations necessitate more complex grid components, including sophisticated protection and power routing devices, as well as advanced control systems. Currently, the market offers a limited selection of components that are ready for these applications, often requiring custom modifications or the use of prototype-level devices in projects.

The selection of an earthing system involves choosing from traditional earthing configurations such as Terra-Neutral Combined (TN-C), Terra-Neutral Separate (TN-S), Terra-Neutral Combined-Separate (TN-C-S), Terra-Terra (TT), and Isolated-Terra (IT), each with its specific considerations. In installations where AC and DC systems are combined, the earthing strategy can be distinct for each if they are isolated from one another. However, when AC and DC systems are not isolated, the choice of earthing on either side should be deliberate, factoring into the design of the protection and conversion stages.

The utilization of multiple earthing points in DC distribution systems is influenced by the grid topology and its integration with the AC system. Earthing in one location, especially on the AC side, can complicate earthing in areas served by DC. For example, in a bipolar system, earthing the midpoint can lead to significant issues. Single-point earthing is generally recommended due to the low risk of pole loading imbalance, which can cause substantial balancing currents to flow if multiple earthing points are used.

DC systems are particularly subject to electrical corrosion due to the unidirectional flow of current and the potential harm stray currents can cause to structural components. It is essential that earthing and isolation schemes address these issues, aiming to minimize ground loop levels and mitigate stray currents. Additionally, DC systems typically involve converters and operate at higher frequencies, which can result in increased leakage currents. These currents require careful management through thoughtful converter design, effective filtering, and proper earthing and isolation strategies.

3.1.2 Corrosion risk under DC distribution

Corrosion can be caused by stray currents, meaning leakage currents flowing through paths other than the intended circuit. In metallic conductor electrical current, electron displacement occurs, while in other media (especially electrolytes), it involves the displacement of ions.

When dealing with AC current, ions move around an intermediate position, posing no issue. However, with DC, ions consistently move in the same direction, leading to electrochemical reactions at the metal-electrolyte interface, resulting in the creation or absorption of ions. Under specific conditions (depending on pH and voltage difference), these electrochemical reactions can lead to the corrosion of the metallic conductor, as illustrated in the Figure 3-1.

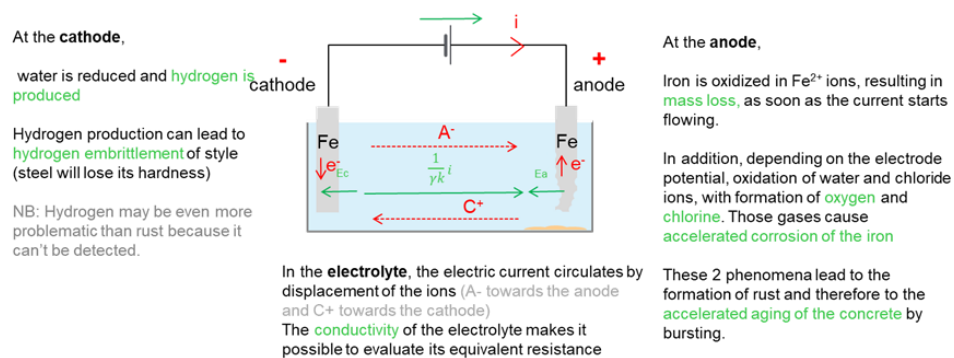

Figure 3-1: Electrochemical Corrosion Phenomena illustration

Even if stray currents are small, corrosion is active wherever current leaves the metal. This consideration is particularly crucial when assessing leakages in the rebar structure of building concrete. The consequence of corrosion phenomena is the formation of rust inside concrete. As rust occupies more space than its original compounds, it accelerates the aging of concrete by causing spalling. Moreover, the resulting cracks facilitate the penetration of oxygen to the iron, and this phenomenon becomes exponential.

3.1.3 Earthing systems

As mentioned in subsection 3.1.2, it is imperative to avoid DC stray currents. Consequently, not all earthing systems are suitable for DC distribution. TT and TN-C earthing systems should be avoided unless specific protection measures are implemented, while TN-S and IT earthing systems may be utilised. Details are presented in the next subsections.

3.1.3.1 TT earthing system

The TT earthing system inherently utilizes the earth as a return path for leakage currents, which means that earthing electrodes will be depleted, and leading to corrosion issues affecting all metallic structures along the return path to the source as illustrated in the Figure 3-2.

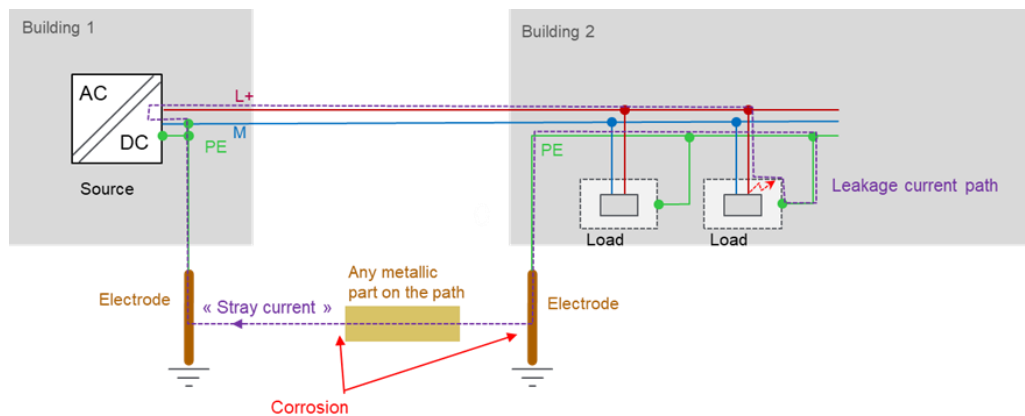

Figure 3-2: DC TT Earthing Configuration

3.1.3.2 TN-C earthing system

In TN-C earthing systems, the Protective Earth (PE) and M conductors are combined (PEM), resulting in voltage drop along the cable when current is carried. This creates a voltage difference across various locations in the building's concrete, leading to stray current circulation. According to EN 12954 and EN 50122-2, cathodic protection standards [36], [37], it's specified that the 200 mV threshold should not be exceeded. The illustration below demonstrates that when current flows through the structure, corrosion occurs (depicted in orange stars) where the current exits the metal, such as equipment screws and non-continuous rebars as illustrated in Figure 3-3.

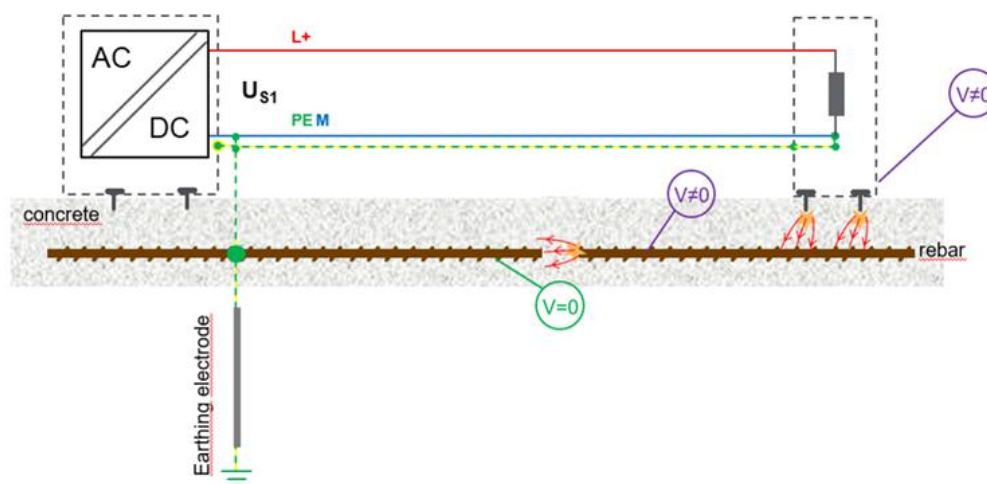

Figure 3-3: DC TN-C Earthing Configuration

3.1.3.3 TN-S and IT earthing systems

Under this earthing system, as illustrated in Figure 3-4 and Figure 3-5, stray currents are designed to be conducted by the Protective Earthing (PE) conductor, preventing their entry into the concrete and rebar structure of the building. However, it is crucial to ensure the continuity and integrity of the PE conductor.

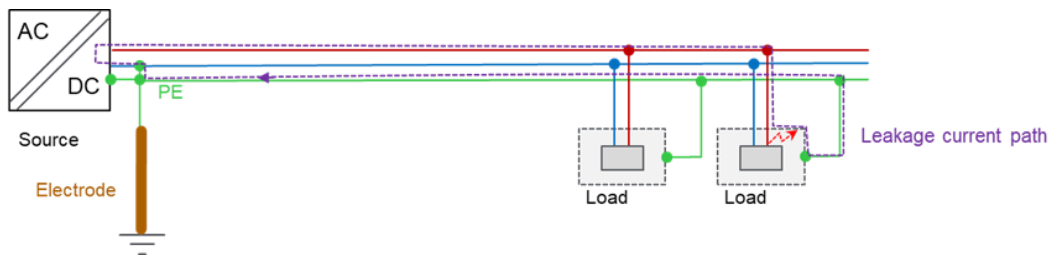

Figure 3-4: DC TN-S Earthing Configuration

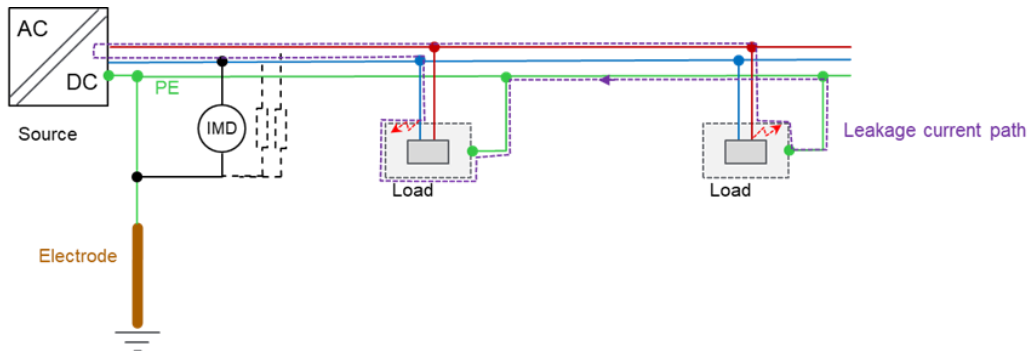

Figure 3-5: DC IT Earthing Configuration

The complexity in designing DC grids arises primarily from the lack of established design rules and industry standards. This elevates the requirements for designers, demanding a deeper understanding of the system, its components, and their interoperation. Selecting suitable components becomes a more challenging task, necessitating a higher level of designer expertise. However, as designers gain experience and standardized practices are developed, it is anticipated that the complexity of DC distribution will decrease, eventually reaching the level of today's AC systems.

3.1.4 Protection

The protection of DC system should address two fundamental distinction of DC system compared to AC. The first one is the lack of periodical current and voltage extinguishing, what is called zero crossing of alternating current. The second one is the capacitive nature of the sources and storage units resulting in fast current raise during transient behaviour or fault. One potential solution to this direction could be the use of semiconductors as power switches, i.e., Solid-State Circuit Breaker (SSCB) or Hybrid Circuit Breaker (HCB).

Solid-state based breakers consist of power-electronic switches that are permanently switched into the conduction path (Figure 3-6 left). They can turn off and interrupt the fault current within a few microseconds. However, as they are permanently carrying the grid current, they cause a lot of additional power loss and hence, the overall efficiency of the electrical distribution is reduced. The hybrid circuit breaker topology (Figure 3-6 right) offers a solution to this problem. A hybrid circuit breaker consists of a mechanical switch and an electric circuit. The mechanical switch has low conduction losses and can therefore be very efficiently integrated into the main conduction path. The electric part of the breaker is only activated when a fault is detected.

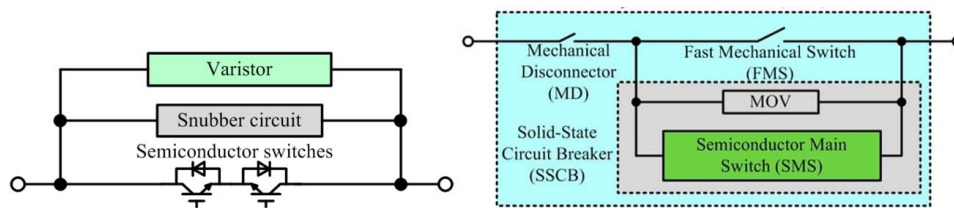

Figure 3-6: Solid state (left) and hybrid (right) circuit breaker designs [38]

3.1.4.1 Protection on Low Voltage power distribution

In the LV area there is a range of protection components existing for example for industrial and photovoltaic DC installations. Main components are same as in case of AC distribution: fuses and circuit breakers. And those components use similar technologies like in AC system with minor adaptation for DC, for example larger contact separation space, adding special magnetic elements. Although those do not address, or address partially or inefficiently mentioned specifics of DC grid.

Therefore, special technical approaches are used for power interruption in the DC distribution. Most common approaches are solid states or hybrid circuit breaker designs using semiconductor switches for interruption of the electrical current. Such devices [39], [40] exist in very limited range of parameters, often in prototype phases, presume specific application rules and does not have long record of utilization. These devices include electronic control and allow more sophisticated configuration and addressing sophisticated conditions and faults, but again lacking extended family of products which makes more difficult selective coordination and zoning design and require higher qualification of the electrical designer and installer. Currently, an updated version of the IEC 60947-10 standard is being developed to include semiconductor circuit breakers.

3.1.4.2 Protection on Medium Voltage power distribution

Circuit breaker for 3kV DC and 1,5kV DC overhead catenaries for trains already exist at the highest Technology Readiness Level (TRL) [26]. However, power supply of trains via DC-catenaries is a very specific application and the properties of the switches, especially their high interruption times, do not meet the requirements from typical MVDC grid applications.

Several protection concepts for MVDC grids are being discussed, but none of them have been standardized yet. One promising approach could be the incorporation of circuit breakers to interrupt the fault current, as it is already be done in ac-grids. Breaker based concepts offer the advantage of separating the faulty part of the MVDC grid from the operable part of the grid, giving the possibility to interrupt supply only for a minimum grid area and rapidly restoring grid operation through reconfiguration. Solid-state based breakers consist of power-electronic switches that are permanently switched into the conduction path. They can turn off and interrupt the fault current within a few microseconds. However, as they are permanently carrying the grid current, they cause a lot of additional power loss and hence, the overall efficiency of the MVDC application is reduced.

The hybrid circuit breaker topology is advantageous for this problem. A hybrid circuit breaker consists of a mechanical switch and an electric circuit. The mechanical switch has low conduction losses and can therefore be very efficiently integrated into the main conduction path. The electric part of the breaker only conducts current when a fault is detected. For MVDC, SciBreak developed a hybrid breaker, which incorporates the Voltage-Source-Converter Assisted Resonant Current (VARC) technology concept. When a fault occurs, the electric circuit superposes the fault current with a current pulse in the opposite direction, forcing the current through the mechanical breaker to zero, allowing it to open without causing an electric arc. A breaker prototype has already been tested in

2018 [41] and the technology is also further developed for 14 kV together with Eaton within other EU-Horizon projects, e.g. the HYPERRIDE project [42]. Another hybrid circuit breaker technology that has been proposed in 2018 is the diode-assisted gate commutated thyristor-based circuit breaker (DAGCT) [43]. If a fault occurs, the power electronic circuit lets the fault current commute from the mechanical breaker to a thyristor, which is then turned off, thus interrupting the fault current. Within the Flexible Electrical Networks (FEN) Research Campus a prototype has been tested in 2023 to interrupt 1,2 kA and the technology is expected to be capable of interrupting up to 10 kA [44]. The amplitude of the fault current and its rise time depend largely on the MVDC system voltage and the size of the capacitors connected to it.

As MVDC voltage levels are not standardized yet, requirements for protection components, such as circuit breakers, may vary depending on the application. Thus, apart from developing protection components that are scalable to different MVDC voltage levels, also breakerless protection concepts need to be further investigated.

3.1.5 Cables

Previous research has shown that LVDC cables are less stressed during DC operation, as there is no skin effect, and the thermal losses are reduced. However, to date, there is a lack of experience on the ageing behaviour of cables and in particular for polymeric insulation under DC stress. As LV electrical installations are expected to operate for several decades, the question of component ageing is a major issue. In this context, designing the right cable for the right installation remains key.

Experimental research has shown that some insulation materials exhibit different ageing behaviour in a DC electrical field than in AC voltage field [45], [46]. In [45] an accelerated thermal electric aging test under DC voltage stress have been conducted under five different groups of insulation materials (PVC, silicone-based, thermoplastic elastomer TPE, polyolefin PO, non-halogen insulation HF). According to results from this research some compounds failed faster in DC than AC. Other polymers have shown equivalent behaviour in DC and AC. In addition to these findings, it seems priority to continue research aimed at understanding what happens in the polymer chemically and physically under dry conditions.

Further knowledge on the failure behaviour and changes in dielectric strength should be considered in deeper. The influence of different flame-retardant components needs to be also considered for compounds used in building environments. In addition, research needs to be carried out in the implantation of the test bench and test conditions used to determine the ageing behaviour.

Hybridization DC/ AC - The solutions already available in the building market (PV, Storage) introduce DC solutions and power. Which means that there can be already, in the building, a mix of DC and AC cables in the same areas, which bring up some challenges, such as if it should be possible to differentiate DC cables from AC cables, and if there any risk for public in case they touch or handling cables. Today, the way to proceed for safety, installations rules, maintenances processes for DC cables are not yet fully defined. There is a work to be done for cable differentiation and the maintenance for hybrid electrical architectures should be defined.

3.1.6 System operation and control

DC power system with the benefit of simpler integration and control of distributed energy resources and storage bring other challenges related the operation of such system. First item to mention connected with capacitive character of sources resulted in high inrush current during transient process. Inrush of this level is capable of damaging semiconductor components and cause nuisance fault detection. To avoid this, strict protocol of device connection and system start-up should be imposed. Device input capacitances should be pre-charged by a controlled current prior to entrance into operation. Similar is valid to the process of shutting down, residual charge will stay on the entrance

capacitances of the devices if all of them switched off, thus, for the maintenance discharging procedure should be implemented.

Another challenge is related to the droop control scheme where devices define its operating mode and balance the system based the voltage level on main DC bus. Measurement imperfections on the devices of different manufacturers as well as voltage drop associated with the losses in the cabling leads to the power sharing offset from the desired value. To minimize its impact on the power system optimal performance a procedure of calibration should be imposed, for instance using secondary control.

Yet another challenge is connecting devices of different vendors having custom communication protocol definition. There are several initiatives of unification of data model of distribution energy resources and storages for each device type [47], [48] but their acceptance level still does not dominate in corresponding markets and data models are not designed for the voltage droop control scheme. Drive for the unification is not strong enough, even in smaller DC distribution market and manufacturers mainly prefer to stay with custom data model and communication scheme. This results in more complex configuration of communication between devices in the power system.

3.1.7 Power electronics converters

Power electronic converters are fundamental devices that play a crucial role in modern electrical systems. These converters facilitate the efficient transformation and control of electrical energy, enabling its optimal utilization across various applications. Depending on the type of conversion the power electronics converters are categorized to AC/DC converters (Rectifiers), DC/AC converters (Inverters), DC/DC converters and AC/AC converters.

DC/DC converters play a pivotal role in various applications due to their ability to efficiently transform DC voltages. These converters enable seamless integration of renewable energy sources (such as solar panels and wind turbines) into grids, ensuring optimal power transfer. Additionally, they facilitate voltage adaptation, power flow control, and isolation, enhancing grid stability and reliability. Whether in microgrids, energy storage systems, or smart grids, DC/DC converters contribute significantly to the modern energy landscape, promoting sustainability and efficient energy utilization.

As regards the DC grids, DC/DC converters play a crucial role, offering several benefits for efficient and reliable operation. More specifically, DC grids often integrate renewable energy sources (such as solar panels and wind turbines) distributed across wide geographical areas. Self-commutated DC transmission technologies, facilitated by DC/DC converters, allow better utilization of these large RESs. They enhance controllability, stability, and resilience to AC and DC faults, enabling efficient power generation from dispersed renewable sources. Additionally, DC/DC converters provide essential controllability for both centralized and decentralized power grids. By adjusting voltage levels and regulating power flow, they ensure optimal operation and stability. This control is especially critical when dealing with intermittent renewable energy resources. In terms of isolation and fault prevention, isolated DC/DC converters prevent fault propagation during pole-to-pole (P2P) and pole-to-ground (P2G) DC faults. They maintain stability by preventing pole shifting in the healthy side. Non-isolated converters offer voltage tapping, matching, and power regulation but cannot prevent pole shifting during faults. Hybrid and resonance-based DC circuit breakers further enhance fault isolation and clearance times.

One of the technical challenges in the rapidly developing market is the need for many Stock Keeping Unit (SKU) types. Wide variety of applications and the lack of proper standardization could result in limited production and, consequently, increase cost of SKUs. Therefore, new power electronic technologies with improved application flexibility are needed to minimize number of SKU types. Such DC/DC converter would greatly simplify design and deployment of non-typical DC installations,

widening outreach of DC technologies in emerging applications. Similar challenges could be observed in the field of electric vehicle chargers, where emergence of 800 V drivetrains has pushed the industry to develop universal chargers with very wide output voltage range.

However, the DC/DC power converters, whether on LVDC or MVDC side, face several technological challenges, each dependent on the specific application requirements:

- **Efficiency:** It is the primary challenge in converting DC power, it can be impacted by switching, conduction and magnetic losses. Thermal management is also a critical aspect in the design to enhance the efficiency.
- **Thermal management:** Heat dissipation shall be efficient to ensure the reliable operation of the DC power converter. Designing efficient cooling mechanisms, heat sinks and thermal interfaces is essential to prevent the components overheating.
- **Switching frequency:** The DC power converter size reduction can be met by increasing the switching frequency thanks to the state-of-the art of Silicon Carbide (SiC) and Gallium Nitride (GaN) MOSFETs. However, it can lead to higher switching losses or enlarged Electromagnetic Interference (EMI) filters.
- **Complex control and steady-state analysis:** DC/DC converters require sophisticated control algorithms to regulate voltage, current, and power flow. Achieving stable operation across varying load conditions and grid disturbances is challenging. Steady-state analysis involves ensuring that the converter operates within safe limits, minimizing losses, and maintaining efficiency.
- **Power flow management:** In multi-terminal DC grids, managing power flow among different ports becomes intricate. DC/DC converters must dynamically adjust their output to balance power distribution and prevent overloading.
- **Protection and fault management:** Robust fault detection and protection mechanisms ensure the reliability and safety of the DC power converters.
- **Modularity and scalability:** LVDC applications like EV charging stations demand modular DC power converters to accommodate varying power and voltage requirements without impacting the system performance. By employing modular designs, converters can easily scale to meet evolving demands while maintaining high efficiency and voltage regulation.
- **Lifetime:** ensure the high reliability of the DC power converter, on the components level such as semiconductors and passive components, by using high-quality materials with the appropriate derating margins. The component heat and power stresses need to be minimized to extend the converter lifetime.
- **Cost:** the cost-effective solutions shall not compromise the performance and the reliability of the DC power converter.
- **EMI/EMC:** the power converter shall comply with the EMI/EMC standards to avoid interference with other connected electronic devices that share the same DC micro-grid. Maximizing the immunity to external disturbances and minimising the radiated and conducted emissions is a real challenge in power electronic designs where the switching frequencies and the voltage are high.

This project addresses the aforementioned challenges by development of novel tools, technologies and devices. For example, micro solar DC systems based on FlexiVerter technology allowing to use the same SKUs for integrating different PV modules and batteries, providing unparalleled application flexibility, system scalability/modularity, and opening potential for cost reduction resulting from mass production of standardized universal SKUs. On the other hand, new tools, like partial power processing, allows to reconsider conventional electric energy conversion approaches and significantly improve efficiency.

3.2 Economical, Regulatory and Standardization

The subject of DC economical, regulatory and standardization will be addressed in a specific SHIFT2DC Task and Deliverable: T1.2 – Policies, Regulatory framework, and Market Architecture and D1.2 – Policies, Regulatory framework, and Market Architecture for DC solutions. However, a very small synthesis of these challenges is described in this subsection, because they are some of the most important challenges in DC tech adoption.

The economic challenges of MVDC and LVDC systems encompass several key considerations:

1. **Initial capital costs:** These costs include equipment procurement, installation, and system integration, pose a significant concern for MVDC and LVDC infrastructure. While advancements in technology may eventually mitigate these expenses, the upfront investment remains substantial. Additionally, ongoing operational and maintenance costs, including monitoring, repair, and personnel training, must be carefully considered to ensure the long-term viability of these systems.
2. **Training:** To support a faster assimilation of LVDC technologies and uses, program training for installers needs to be designed and deployed in the short term. In addition, LVDC tools to design the best appropriate safe, technical, economic, and environmental solution must be available to ensure the transition from pilots to commercial projects.
3. **Certified products:** Product catalogues and certified products are essential for rapid adoption of the LVDC technologies.
4. **Conversion Costs:** In many cases, existing infrastructure may need to be upgraded or retrofitted to accommodate MVDC or LVDC systems. This can involve additional costs for converting existing AC systems to DC, including the installation of converters, transformers, and other necessary equipment.
5. **Grid Integration Costs:** Integrating MVDC and LVDC systems into existing grids may present challenges and additional costs. This includes ensuring compatibility with existing infrastructure, addressing grid stability issues, and implementing necessary grid reinforcement measures to support the new DC technologies.
6. **Regulatory and Policy Considerations:** Regulatory frameworks and policies can significantly impact the economic viability of MVDC and LVDC systems. Uncertain or unfavourable regulatory environments may deter investment or impose additional compliance costs on stakeholders.

Addressing these economic issues require careful planning, cost-benefit analysis, and collaboration among stakeholders to ensure that MVDC and LVDC systems are deployed in a cost-effective and sustainable manner. These, along with other challenges, will be dealt in detail in the SHIFT2DC project.

Furthermore, and regardless of the voltage level, there is a lack of definition, standardization, and regulations for DC networks. In this subsection, a summary of available standards is presented, based on databases from Institute of Electrical and Electronics Engineers (IEEE) and International Electrotechnical Commission / European Committee for Electrotechnical Standardization (IEC/CENELEC), as well as technical Working Groups (WG) and committees that drive their development such as CIGRE and IEC. Additionally, an independent initiative – Current/OS Foundation– is described.

The table below outlines the contributions of various entities to the standardization and legalization of DC grids.

Table 3-1: Brief synthesis of DC applicable standards

Cigre			
Scope	Code	Title	Description
HVDC, MVDC	B1	Insulated Cables, for both HVDC (WG B1.83) and MVDC (B1.82).	A technical report on AC/DC insulated power cables for power transmission, distribution and generation connections.
HVDC, MVDC	B4	DC-DC converters in HVDC grids and for connections to HVDC systems	A comprehensive evaluation of DC-DC feasibility converters for applications within DC transmission grids.
MVDC, LVDC	C6	Active Distribution Systems and Distributed Energy Resources, with its WG	Explores innovative solutions for DER and distribution systems including MV/LV DC systems
MVDC, LVDC	C6/B4.37	Medium Voltage DC distribution systems.	Comprehensive technical brochure and state of the art on MVDC and LVDC.
IEC			
LVDC, MVDC, HVDC	TC 8	System aspects of electrical energy supply	Responsible of ensuring the consistency of the IEC publications in the fields of horizontal standards.
LVDC, MVDC, HVDC	TC 13	Electrical energy measurement and control	Standardization of AC and DC electrical energy measurement and control, for smart metering equipment and systems forming.
MVDC, HVDC	TC 14	Power transformers	Standardization of power transformers, reactors, their auxiliary, neutral earthing devices.
MVDC, HVDC	TC 20	Electric cables	Standardization of design, testing and end-use recommendations of insulated electrical power and control cables, for use in wiring and in power generation, distribution, and transmission.
LVDC, MVDC, HVDC	TC 22	Power electronic systems and equipment	International standards on systems of electronic power conversion and electronic power switching, including the means for their control, protection, monitoring and measurement.
LVDC	SC 37A	Low-voltage surge protective devices	Surge Protective Devices (SPDs) for protection against indirect/direct effects of lightning and/or against other transient overvoltages.
LVDC, MVDC, HVDC	TC 57	Power systems management and associated information exchange	International standards for power systems control equipment and systems including EMS, SCADA, distribution automation, and associated information exchange for non/real-time information.

LVDC, MVDC, HVDC	TC 82	Solar photovoltaic energy systems	International standards for systems of PV conversion of solar energy into electrical energy and for all the elements in its system.
MVDC, HVDC	TC 88	Wind energy generation systems	Standardization in the field of wind energy generation systems including wind turbines, wind power plants onshore/offshore and interaction with other electrical systems.
MVDC, HVDC	TC 99	Insulation co-ordination and system engineering of high voltage electrical power installations above 1,0 kV AC and 1,5 kV DC	Standardisation the specify: a) basic principles of insulation co-ordination for high voltage systems, b) common rules and particular requirements for system engineering and erection of high voltage electrical power installations.
LVDC	TC 109	Insulation co-ordination for low-voltage equipment	International standards on the principles of insulation coordination applicable to all LV equipment; up to and including 1kVac. and 1.5kVdc.
HVDC	TC 115	HVDC transmission for DC voltages above 100 kV	Standardization in the field of HVDC Transmission technology above 100kV.
LVDC, MVDC, HVDC	TC 120	Electrical Energy Storage (EES) systems	Standardization in the field of grid integrated EES systems in order to support grid requirements.
LVDC	TC 121	Switchgear and control gear, and their assemblies for low voltage	International standards for LV switchgear and controlgear equipment for industrial, commercial and similar use rated below or equal to 1 kVac and 1,5 kV dc, electromechanical as well as semiconductor (solid state) equipment.
LVDC	SyC LVDC	LVDC and LVDC for Electricity Access	Standardization in the field of LVDC to provide systems level standardization, coordination and guidance.
IEC/IEEE			
HVDC	IEC/IEEE 60076-57-129:2017	IEC/IEEE International Standard - Power transformers – Part 57-129: Transformers for HVDC applications	This part specifies requirements of liquid-immersed converter transformers for use in HVDC power.
HVDC	IEC 61378-3:2015	Converter transformers - Part 3: Application guide	Provides information related to industrial and HVDC converter transformers differing from conventional transformers.
HVDC, MVDC	IEEE 2800-2022	IEEE Standard for Interconnection and	Presents the minimum requirements for the interconnection, capability,

		Interoperability of Inverter-Based Resources (IBRs) Interconnecting with Associated Transmission Electric Power Systems	and lifetime performance of inverter-based resources.
HVDC	IEC TR 62543:2022	HVDC power transmission using voltage sourced converters (VSC)	General guidance on VSC used for transmission of power by HVDC.
HVDC	IEC 60071-11:2022	Insulation co-ordination - Part 11 : Definitions, principles, and rules for HVDC system	IEC 60071-11:2022 applies to HVDC systems. This document gives the insulation co-ordination principles related to LCC and VSC HVDC systems.
HVDC	IEC 62747:2014+ AMD1:2019	Terminology for VSC for HVDC systems	Defines terms for self-commutated VSC used for transmission of power by HVDC.
HVDC	IEC 62501:2009+ AMD1:2014+ AMD2:2017	VSC valves for HVDC power transmission - Electrical testing	Applies to self-commutated converter valves, for use in a three-phase bridge VSC for HVDC power transmission.
HVDC	IEC 62751-1:2014+ AMD1:2018+ AMD2:2022	Power losses in VSC valves for HVDC systems - Part 1: General requirements	General principles for calculating the power losses in the converter valves of a VSC for HVDC applications, independent of the converter topology.
HVDC	IEC TR 63363-1:2022	Performance of VSC based HVDC transmission - Part 1: Steady-state conditions	Presents the "state of the art" with respect to general guidance on the steady-state performance demands of VSC HVDC transmission systems.
HVDC	IEC 62895:2017	HVDC power transmission - Cables with extruded insulation and their accessories for rated voltages up to 320 kV for land applications - Test methods and requirements	Specifies test methods and requirements for fixed land installations, for rated voltages up to and including 320 kV.
HVDC	IEC TS 61973:2012+ AMD1:2019	HVDC substation audible noise	This standard considers the outdoor audible noise from HVDC substations.
HVDC	IEC TS 62344:2022	Design of earth electrode stations for HVDC links - General guidelines	This standard applies to the design of earth electrode stations for HVDC links.
HVDC	IEC TR 62681:2022	Electromagnetic performance of HVDC)overhead transmission lines	Provides general guidance on the electromagnetic environment issues of HVDC overhead transmission lines.
HVDC, FACTS	IEC TR 61850-90-14:2021	Using IEC 61850 for FACTS (Flexible Alternate Current Transmission Systems), HVDC transmission and power conversion data modelling	Focuses on the communication between control system of FACTS, HVDC and Power Conversion and SCADA and HMI systems.

MVDC, LVDC	IEC 62053-41:2021	Electricity metering equipment - Particular requirements - Part 41: Static meters for DC energy (classes 0,5 and 1)	This standard applies only to static watt-hour meter for the measurement of DC electrical energy in DC systems.
-----------------------	--------------------------	---	---

Out of traditional standardization workgroups, one foundation worth noting is Current/OS Foundation. Its mission is to provide access to Intellectual Property (IP) for safe and stable LVDC-based infrastructures, in which congestion is avoided without central control. Current/OS Foundation has defined a Set of Rules, available to any product manufacturer partnered with them, which cover operating voltages and limits, droops, power management, communication models, Electromagnetic Compatibility (EMC) requirements, safety wires, and devices calibration. Manufacturers like Schneider Electric, DC Systems, and Eaton support this Foundation.

Additionally, standards for modern DC systems aren't necessarily written from scratch; many emerging standards are updates or amendments of previously issued norms, whether for LCC-based HVDC or even AC systems. Subjects such as power quality and protections, for example, are very likely to appear in future versions of existing documents. The same may apply to MVDC, which could be included in the scope of some HVDC or LVDC standards.

In summary, HVDC technology is more well-defined and standardized compared to MVDC and LVDC. However, both MVDC and LVDC require processes to address their economical, regulatory, and technical standardization challenges. For instance, the HVDC cable industry is more mature, while MVDC standards are relatively established. In contrast, LVDC standards are still in early stages, with existing standards covering LVAC up to 1 kV and LVDC up to 1.5 kV.

3.3 DC Eco-Systems

In today's fast-paced digital economy, it's crucial for all companies, regardless of their stage of development, to recognise that DC innovation cannot occur in isolation if substantial change is to be realised. This section elaborates on the challenges related to adopting DC systems.

3.3.1 The challenge of distribution grids

With the worldwide energy scene rapidly evolving, marked by a growing dependence on renewable energy sources and the widespread electrification of transportation and buildings, the electrical grid system is encountering substantial challenges:

- The dependability and accessibility of electrical power supply and public networks are becoming increasingly of critical concern.
- DC sources and loads are all around us.
- E-mobility and digital technology are escalating the electrical power demand and requirements of DC loads.
- DC standards are not clearly defined.
- Bidirectional power flows are becoming the norm.
- Any change requires a social consideration.
- Cybersecurity and cyber-resilience are becoming areas of concern.

3.3.2 Countries already facing capacity challenges

The worldwide community acknowledges the need to reduce carbon emissions, with countries consistently pledging to decrease our carbon footprint and reliance on fossil fuels.

However, the inability to charge electric vehicles or power buildings could pose a significant issue. This is already a reality in Europe, extending beyond countries with inadequate or poorly equipped public networks. The today's situation in Netherlands is an example. The country is facing challenges with their distribution grid due to high solar power and electric vehicle adoption rates, above the European average as depicted in Figure 3-7 [49]. Renewable energy sources (solar, wind, biomass) already constitute nearly 40% of their energy mix, compared to the EU's 15% [50].

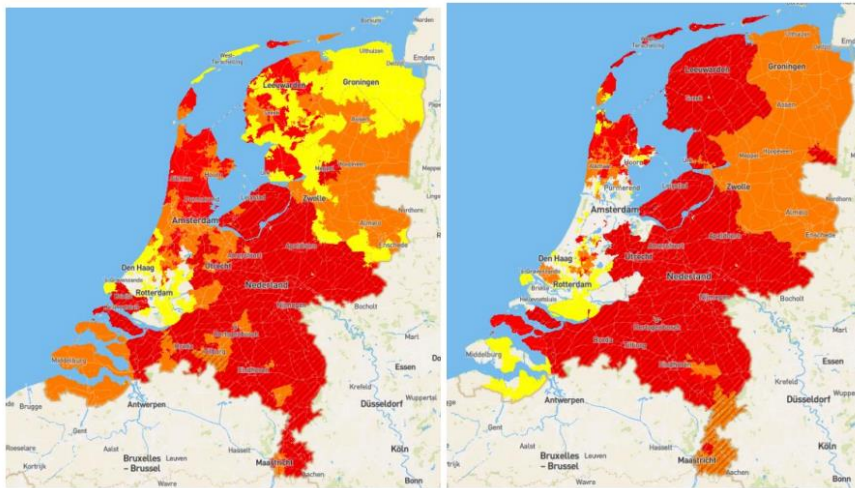

Figure 3-7: Grid availability for new load (left) and feed-in (right) for users above 3*80 A [49].

This issue is not unique to the Netherlands but is widespread across regions such as southern England, western Germany, northern Italy, California... Consequently, property and industrial investment initiatives are being deferred due to the inability of distribution networks to cope with the increasing demand.

Another significant factor causing increased grid congestions is population density. In north and north-east EU, population density is much below average, resulting in limited outreach and capacity of electric grids. On the other hand, these countries actively support residential renewable energy deployment and adoption of green mobility. These trends, combined with wider deployment of single-phase chargers, heat pumps, PV inverters, and other equipment, result in increased grid congestions across the region.

Traditional AC distribution systems, designed decades ago for centralized generation, are struggling to accommodate the rise in distributed energy resources and bidirectional power flows, while concerns about grid resilience are compounded by aging infrastructure and climate change impacts. Innovative approaches are required to optimize power distribution capabilities and modernize energy systems for a sustainable future.

3.3.3 Our daily lives are all around DC sources and DC loads

Most of today's devices, such as phone or laptop chargers, consume DC energy, yet they rely on converting AC energy from the grid to function. Furthermore, many decentralized energy sources like solar panels and batteries inherently produce DC power, requiring converter systems to transform it into AC. These repeated conversions result in energy losses, estimated to be as high as 10-15%.

Distributing electricity in the form of DC over long distances also leads to reduced transmission losses compared to AC networks. This enhances the capacity to incorporate decentralized renewable energy sources without the need for expensive grid reinforcements. DC microgrids also offer the flexibility of integrating various local resources such as batteries, electric vehicles, and generators, acting as distributed energy reserves.

By not relying on synchronized frequency control, DC networks demonstrate greater operational resilience. They can continue to power critical loads by seamlessly isolating themselves during AC grid disturbances. In contrast to rigid tree-like structures, mesh-connected DC systems achieve higher redundancy through multiple power pathways. Incorporating smart DC-DC conversions enables responsive virtual inertia emulation and congestion management without central coordination.

This re-invented distribution grid adopts a holistic approach, integrating self-sustaining renewable energy, storage, and self-regulating smart converters. This approach makes it compelling, even necessary, to develop an ecosystem that facilitates the seamless and flexible use of products from different manufacturers.

3.3.4 Addressing Resilience through Control Standardization

One of the challenges lies in the absence of clearly defined electrical distribution standards. Consequently, the goal is to establish regulations for electrical distribution that would allow manufacturers of various products like dishwashers, photovoltaic panels, and electric vehicle chargers to operate, for example, at a common voltage.

This is a primary focus of some organizations, aiming to create standardized rules that enhance the resilience of DC microgrids, whether connected to the grid or operating autonomously. By defining standardized voltage and current profiles for sources and loads using "droop control" logic, the microgrid achieves stable autonomous power sharing.

The underlying principle involves loads adjusting their consumption based on measured voltage conditions, prioritizing critical services during lower power availability, and allowing all loads to consume full power during higher availability. Additionally, the microgrid can feed back power supply to the grid. This "droop control" logic optimizes and reduces power demand from the grid, potentially aiding real estate developers in obtaining building permits.

This easy management and permanent adaptation of the priorities at sources, loads, or batteries/battery blocs level, makes the system bidirectional by default. It eases the import or the export of power.

By converging technical criteria, the aim is to simplify the multi-vendor designs, procurements, and installations. Ultimately, the specifications establish unified rules for replicable and upgradable microgrid architectures worldwide.

3.3.5 Cyber issues and concerns

The "droop control" logic also tackles another challenge, which is the cybersecurity risk. The system natively adjusts the level of power, either by controlling and prioritizing the loads consumption, or by feedbacking the power to the grids or batteries. Without the need for centralized real-time coordination and control software, this logic effectively guards against cybersecurity issues.

3.3.6 Advancing Global Adoption within the eco-system

As previously mentioned, establishing an ecosystem is essential to promote the adoption and flexible utilization of products from various manufacturers worldwide.

Dedicated organizations, such as the Current/OS Foundation and the Open DC Alliance (ODCA), are focused on developing this ecosystem. These non-profit, collaborative organizations bring together equipment manufacturers, designers, installers, utilities, laboratories, research institutes, and other stakeholders. For example, the Current/OS Foundation is leading a panel of more than 40 partners.

Emphasizing standardization helps mitigate the risks of market fragmentation, promoting technology investments for manufacturers by expanding potential opportunities. It is crucial for organizations and companies to engage in promotional, certification, and educational initiatives to streamline regulatory approval processes and foster industry expertise on a global scale.

For instance, the Current/OS Foundation aims to ensure that DC microgrid standards progress openly, drawing from practical field experiences. It manages a network of certified DC products according to an established certification scheme. By providing manufacturers with unified regulations for system integration and interoperability validation, the Foundation simplifies the adoption of technology while upholding safety as a primary concern. The standards also ensure enhanced local grid stability by enabling multi-vendor solutions to operate cohesively according to the same set of rules, thereby reinforcing microgrid immunity to uncertainties from unpredictable factors.

Collaborations with international certification bodies not only enhance technical recognition but also address safety codes. The above-mentioned organizations are also collaborating with organizations like EMerge Alliance in the US, and China Association of Building Energy Efficiency (CABEE) to align global visioning efforts. Additionally, as a liaison member, the Current/OS Foundation actively contributes to IEC standardization Working Groups, sharing expertise gained from real-world deployments.

By streamlining interconnected distributed energy systems, the adoption of common rules reduces costs, enabling greater access to clean technology. These rules promote resilience across diverse climates and economies. As global electrification expands, playing a pivotal role in achieving a sustainable DC-enabled energy future through open standardization is crucial.

The shift towards electrification, moving away from fossil fuels, will lead to an increase in the demand for electrical energy. Existing systems are designed for peak usage, and the growth in energy demand will necessitate an upgrade to the power system.

These challenges can only be overcome through a concerted and widespread adoption of common rules by various stakeholders, including electrical equipment manufacturers (both energy sources and consumer loads), installers, design offices and architects, universities, and utilities. These rules require collective convergence mainly on various voltage levels, “droop control”, earthing schemes, and circuit protection. The innovative work of organizations such as the Current/OS Foundation or ODCA address critical grid modernization needs through convergence on reliable DC architectures.

3.4 Stakeholder Acceptance

Social benefits of DC microgrids include affordability of electricity rates, improved quality of life and quality of productivity, job creation, and energy poverty reduction [51], [52], [53].

Transition to DC solutions has an impact on the consumer end [54], so this brings attention to the assessment of non-technical factors influencing consumer’s acceptance of the establishment of DC solutions, which is a less researched area [54], [55], [56].

This section explores published reports and/or peer-reviewed literature on identifying influencing factors of customers of DC solutions.

A study in the Netherlands by [55] reveals that people's acceptance of DC houses relies on a good attitude towards the DC house and a strong desire to buy them; also, future acceptability depends on

participants having a positive attitude towards sustainability. Another study, in Sri Lanka Field [57], highlighted ease of use as the most prominent factor influencing people's adoption of DC microgrid solutions in buildings, among other two (relative advantage and perceived behavioural control).

On the other hand, in the USA, the authors of [58] presented technology readiness as a driving factor for DC adoption in residential DC backup circuits and community microgrids. In another study in the USA [56], the authors presented the obstacles to the adoption of DC solutions, which are: the lack of familiarity among industry experts, tiny markets for DC components and devices, and poor public perceptions of DC technology, which leads to concerns regarding the event of an electric shock and fire hazard. Additionally, consumers' fundamental lack of familiarity with DC power systems may cause concern among the public about the reliability and cost of DC circuits and devices.

In the work presented in [59], Chang & Hung used a framework to categorize factors influencing the adoption of net zero energy buildings in Thailand into a Technological (relative advantage, complexity, technology readiness), Organizational (top management support, organization readiness), and Environmental (regulations, vendor's support) framework.

The leading influencing factors presented from the included publications above are mostly from the wide used *technology acceptance theories*. There are different theories on user adoption of technology (like the Technology Acceptance Model - TAM [60], the Pleasure, Arousal, and Dominance paradigm of affect [61], Consumer Acceptance of Technology - CAT (Kulviwat et al., 2007), Theory of Planned Behaviour, Unified Theory of Acceptance and Use of Technology – UTAUT [62]).

While some of the theories, like the Consumer Acceptance of Technology, were developed from the Technology Acceptance Model and the Theory of Reasoned Action [63]. A study by FakhrHosseini et al. [64] shows that theories integrate multiple aspects of technology adoption by considering the attributes of the user, system, environment, tasks, and context. This raised major concerns regarding the generalizability of application of existing theories to emerging technologies such as DC.

Furthermore, due to the lack of real-world pilots and demonstrations of DC technology, it may be challenging to adopt and validate such technology acceptance theories. In this regard, other methods can be considered, such as expert elicitation [65] and future studies [66].

Expert Elicitation (EE) is a method used in various fields, including science, engineering, and decision-making processes, to gather and synthesize expert opinions on topics where empirical data might be scarce, uncertain, or inaccessible. It involves systematically soliciting and aggregating judgments from individuals with relevant knowledge, experience, and expertise in a particular subject area – i.e., experts. Considering the current state-of-the-art concerning DC implementations, this method is well suited to analyse non-technological factors such as public perceptions and market growth.

Future studies (FS), or futurology or futures studies, is an interdisciplinary field that explores and analyses possible futures. It aims to understand, anticipate, and prepare for potential developments, trends, challenges, and opportunities that may arise in various aspects of human life, society, technology, economy, environment, and beyond. Unlike EE, FS does not rely solely on experts, making these techniques adequate to understand better aspects related to the future everyday users of the technology, e.g., retailers, industry stakeholders (e.g., Port managers), and the final electricity consumers.

In summary, the literature search shows that there is a scarcity of papers and/or reports on the assessment of social influencing factors on the adoption of DC technology in smart grid solutions [54]. Still, a critical step towards understanding customer acceptance is to find and comprehend the aforementioned methodological aspects to decide the most adequate research methodologies to adopt in the scope of the SHIF2DC and other related projects.

4 DC Opportunities and Evolution Scenarios

Now that the main Applications and Challenges of Direct Current are thoroughly described in the previous section, it's time to embrace the great opportunities for the energy sector that arise from the adoption of DC in the mentioned applications. Thus, in this section, for each type of application, the opportunities and evolution scenarios for DC tech will be presented by author's point of view, and more importantly, that should be the target of development and demonstration in the SHIFT2DC project.

4.1 Industry

In the industry, very high demands are placed on the supply quality and availability, in order to be able to operate the individual industrial processes reliably. This is where DC power grids come in, which can be coupled very efficiently to additional BESS and thus provide additional security of supply.

The advantages of DC grids are manifold. They offer high efficiency and reliability and have the advantage over AC that they do not generate any reactive power and therefore do not require any compensation systems. They also enable the reduction of high-loss AC/DC conversions and a low-loss feed-in of renewable energy.

In addition to the general advantages of DC, such as energy efficiency due to the elimination of rectifiers in the components and thus the elimination of energy loss due to the conversion of AC to DC, there is also better resource efficiency. Cables require fewer wires and have a smaller cross-section due to higher voltages [67]. This reduces the need for copper in the infrastructure. For example, a voltage of 650 V DC has emerged as a favourable nominal voltage in industry and thus this level is significantly higher than the usual AC voltages in low voltage.

Furthermore, direct current offers the advantage that the elimination of AC reduces disruptive voltage fluctuations, resulting in fewer grid disturbances. This has a positive effect on industrial production, as many production processes are sensitive to voltage fluctuations and production downtimes can possibly even be avoided.

The increasing use of renewable energy directly at the industrial process site in the form of photovoltaics systems can also be efficiently integrated into the DC power grid without intermediate conversion to AC. The same applies to the integration of battery storage systems, which can also support the security of supply of the industrial grid against short-term interruptions, voltage fluctuations and other failures of the central supply or even take over completely for a limited period of time. In this way, it is also possible to efficiently implement stand-alone grid operation and, in principle, enable black start capability.

Although electrolysis plants and fuel cells using larger storage volumes of hydrogen as an intermediate step for energy storage do not stand a chance in terms of cost today, their use in the future may well be interesting, especially as they can store significantly larger amounts of energy in the medium and long term. Whether this will also be economically viable on the scale of industrial properties or whether it is more likely to be found on a larger scale in the public supply network is still an open question. Irrespective of this, this represents an analogy to the battery storage system in terms of integration into a DC grid. On the other hand, some industry sectors, like chemical, use hydrogen in large quantities for the technological processes and may benefit from on-site production of green hydrogen to decarbonize their operation. Though not yet established but with ambitious goals, some steel manufacturers strive for hydrogen for the steel production which could also save reasonable amounts of CO₂.

In addition to the technical advantages, efficiency and resource savings offer cost-saving potential, which is particularly advantageous when electricity prices are rising.

Obviously, there is sufficient motivation for the use of DC in industry and its variety of applications. The question therefore arises as to why this has not been implemented on a large scale for a long time.

First and foremost, this can be explained historically. In the meantime, power electronics have made it possible to exploit all the advantages of DC technology efficiently, reliably and cost-effectively. However, the portfolio of components for the emerging voltage in an industrial environment is still rare and not available in the quantities that are offered for the AC world. In addition, there are still standardization activities around protection concepts, among others, so that an evolutionary development beyond previous individual devices and systems can still be expected here. The availability and cost structure for DC components in the relevant voltage level and the required performance classes will therefore gradually improve.

It is obvious that the development towards extensive DC grids in industry will take place via the following evolutionary steps:

Starting from individual applications whose specific requirements are already being met today, and are therefore already being implemented, the expansion will extend to use in more extensive processes or production lines.

If necessary, parallel production lines in the portfolio can be converted to DC one after the other or new production lines can be added directly to DC supply, thus enabling a gradual migration. It may be possible to achieve this at low cost during the factory's operations if the capacity utilization of the lines varies. Once production as such has been converted to DC, the next stage can be a complete migration of building technology such as lighting, HVAC and IT. If necessary, even before the industrial processes are migrated, so that the entire production facility is ultimately converted to DC.

However, the construction of new production facilities from scratch based on DC supply is likely to be much simpler and therefore predominant.

Depending on the scenario, the DC grid can be powered by a central rectifier connected to an upstream AC grid, as will often be the case with new facilities, or in the form of decentralized rectifiers to supply individual processes or systems, as will be the case with the gradual migration of existing AC applications in particular. Any mix in between, combining some applications, processes or production lines to individual DC bus bars, is also likely to be found.

For an internationally accepted and interoperable use of DC grids in industry, however, some standardization issues still need to be clarified. The ODCA, which aims to promote the evolution towards DC, are committed to the rapid dissemination and support of the use of DC in industrial applications. Finally, DC demonstrators, proving and showing the advantages of the DC technology will be the trigger for many companies to following the established examples of a reliable operation of a DC infrastructure, which is also one of the main goals of the project.

4.2 Ports

Port infrastructures are vital to the EU economy, responsible for 74% of exported and imported goods and 37% of intra-union trades. Out of all the EU ports, 319 were identified as critical seaports in the TEN-T [68], out of which 83 belong to the core network and 236 belong to the comprehensive network. TEN-T's objective is to develop an efficient and high-quality transport infrastructure for people and goods, strengthening the EU's economy and territorial cohesion. The core network is expected to be completed by 2030, while the comprehensive network will be completed by 2050.

In 2013, the EU identified three significant challenges for Europe's Seaports: Expected growth of cargo handled in EU ports demands facility investments to accommodate increased traffic; The ports must adapt to ultra-large container ships as well as new types of ships requiring new paradigms in SSE; The performance gap between the main EU ports leads to inefficient routes and more transport emissions [69]. These challenges triggered the commission to invest in modernising the seaport infrastructure.

Besides the critical need for efficient maritime connections, seaports also play a significant role in sustainability. Seaports manage the supply chains, logistics and supporting infrastructure for offshore wind energy production. Seeking to reduce EU oil dependency, the current legislative framework has mandatory requirements for SSE infrastructure to supply passenger and container ships with gross tonnage above 5000 Gton at the beginning of 2030 [70].

The above-detailed vital role of Europe's seaport infrastructure attracts billions of EUR of private, national and EU investment. In summary, all the above represents a conjecture for a massive investment in seaport infrastructures and facilities, where DC transmission and distribution technologies and other DC technologies can have a thriving development space.

The currently most prominent application is the fast charging of onboard ship batteries with actual systems already in an operational environment (highest TRL). Several plug-in ships are already deployed and use DC charging systems with charging powers up to 4 MW [13]. Different power systems architectures are possible, and their arrangements vary regarding the accommodation of various auxiliary services and include systems where the DC bus can accommodate other systems such as PV [71]

The European Maritime Safety Agency (EMSA) published 2022 and revised 2023 guidelines for the use of SSE systems [9], [72]. In these documents, the use of DC power infrastructure is referred to as having a limited expression of application as of today. Nonetheless, in the different configuration options provided in the guidelines, a specific mention is made of DC distribution systems in HV, MV and LV. The document also lists the advantages of DC power transfer systems, such as increased power transfer efficiency, transfer power independent of distance, enabling the operation of asynchronously operating power systems and quick control of volume and direction of power flow. The main listed disadvantage is the limited technological availability that, while it represents a challenge, is also an opportunity for emerging DC technologies.

All the applications to seaports listed in Section 2.2 represent entry opportunities for the penetration of DC-based solutions in this sector. Developing these technologies is an opportunity to cement EU companies and technology at the forefront of the DC distribution and transmission system, consequently placing them in positions to export this technology outside the EU.

The standardisation for interconnectivity and interoperability poses both a challenge and an opportunity for DC systems. The IEC/ISO/IEEE 80005-1 and 80005-3 define requirements for the shore connection design while guaranteeing safety and compatibility between ships with HV and LV shore connections, respectively. However, no standardisation prevails for the interoperability and interconnectivity of shore-side battery charging in DC. However, the potential flexibility in the design of DC power systems allows for the relaxation of the requirements for the connections of ships to shores. Even with no DC connection to the Ship, a DC distribution system can easily accommodate both 50Hz and 60Hz ships with a single inverter, removing the requirements for line frequency converters or custom port connections [11].

This flexibility, characteristic of DC power systems, can also enable opportunities to create DC eco-systems. The power availability can be such that a DC distribution system can power all the facilities in seaports, from people to cargo management, from subsidiary port companies to industries that typically are near seaports. Such an eco-system makes it so that ports can actively serve ancillary grid services given the availability of power required for the berthing of ships. A complete DC power system

port infrastructure can also benefit and contribute to currently under-development standards such as Current/OS and OCDA.

The timeline for the TEN-T network is both an opportunity and a challenge for the penetration of DC distribution systems. On one hand the massive investments for the modernization of seaport facilities can open space for new DC technologies, on the other hand, the fixed timeline for 2050 requires a leap in the maturity of DC technologies.

Energy efficiency has been identified by the European Sea Port Organization as one of the most important environmental priorities in ports [73] therefore the optimization of CI technology with the integration of RES and ESSs and other fuel alternatives such a hydrogen into the port's power systems using a DC network can be surely a way to address these issues.

4.3 Data Centres

The increasing prevalence of digitalization, including technologies such as the IoT, cloud applications, AI, or autonomous driving, results in a growing demand for European data centres as shown in [28]. Simultaneously, there is a need for a more resilient IT infrastructure and reduced dependence on non-EU countries.

The increasing demand for computational resources contributes to a rise in energy consumption and subsequent CO₂ emissions. Therefore, ensuring the efficiency of data centres is crucial for the European Union's objective of achieving climate neutrality by 2050. However, [29] indicates that improvements in PUE have reached a plateau, with the most cost-effective measures, particularly in cooling systems, already implemented. Consequently, a more disruptive approach is required to further enhance PUE. According to [74], power distribution accounts for approximately 8% of data centre energy consumption. Transitioning the overall electrical architecture to DC has the potential to improve efficiency by reducing conversion steps and minimizing conduction losses.

While the severity of outages is slightly decreasing, power-related issues is still the primary cause of outages in data centres [29]. A DC distribution can improve the overall reliability of a data centre. Firstly, the easy integration of renewable energy sources becomes feasible with DC power, enabling a more sustainable and resilient energy supply. Additionally, the scalability of backup battery systems can be improved, ensuring uninterrupted power during outages. Moreover, by reducing the number of conversion steps, a DC distribution system minimizes the components that are susceptible to malfunction or failure, thereby enhancing system reliability. Furthermore, a DC based power architecture can be realized in a decentralized way. This allows for better maintenance, leading to improved availability and a reduction of the impact of malfunctions and human errors, which are confined to smaller areas within the data centre. On top of that, due to the reduction of components, the converters and devices have the potential to be more cost efficient in production, provided similar economies of scale. Overall design of converters is simpler as well. A common problem in UPS power supply development are harmonics and phase balancing in order to keep THD and unbalanced neutral currents low [75], which are inherently AC problems and do not exist at this scale in DC systems.

As described in chapter 2.3, edge data centres are expected to represent on a greater share of the overall server capacity. While several efficiency measures are not viable on the smaller scale that edge data centres represent, an integration of the cooling system into the communal heating or warm water system can be realized with relatively low effort.

With computing load being a DC system, overall power distribution and supply with DC has been a topic within the data centre community for quite some time. 48 V has been used in the Telco applications for decades and as such a wide range of products and technologies for switchgear and distribution are available, as well as ICT equipment. Therefore 48 V is a voltage level that can be found

in various data centres already, especially on rack level, where some industry standards [76] are already in place as well. Since IT Power Supply Units (PSUs) generally contain two stages of conversion, UPS functionality can be moved inside the rack, resulting in a standard AC distribution but gaining some benefits from a DC application like a reduction in conversion steps. As such, especially for small scale data centres for example in the edge application, 48 V is an interesting voltage level [77]. Also, for existing data centres, this approach can be used for retrofitting without having to change the entire infrastructure and as such keeping the retrofitting costs low. A resulting architecture is shown in Figure 4-1. Energy efficiency is increased by a reduction of the number of power conversions in the prime power path (from utility to load) as well as from a reduction in the oversize ratio enabled by aggregating PSUs and providing the potential for N+1 redundancy.

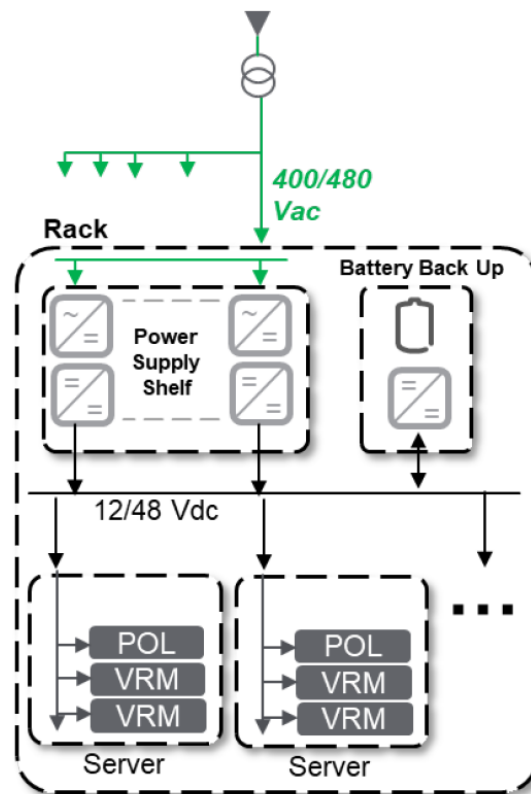

Figure 4-1: Data centre power architecture with a Rack-level DC-distribution

For hyperscale and cloud data centres, the second rising market, a 48 V distribution voltage would increase the CAPEX immensely due to the vast amount of copper needed to carry load currents of multiple kA without too large voltage drops a distribution loss. Voltages of up to 400 V have been discussed in literature [78], [79] and a few pilot data centres have been deployed following a 380 V European Telecommunications Standards Institute (ETSI) standard as well. While this voltage level reduced losses and the required copper cross sections, the number of available components, especially switchgear was limited in the recent history. However, with electric vehicles have pushed the market for protection and switchgear in a similar voltage area forward immensely within the last few years.

Designing a DC based data centre results in a completely different electrical system compared to a standard AC solution. As such, the overall system design can be challenged altogether, and instead of a classic n+n architecture a more modular approach can be utilized. A n+x architecture can offer a similar reliability with a reduction in overall components and as such CAPEX and is easier to deploy in DC as it is in AC.

To summarize, DC offers a vast array of benefits in the application of data centres. The exact realization heavily depends on the use case and type of data centre at hand. For large scale facilities, retrofitting would result in immense costs, since it would result in changing the entire electrical installation, retrofitting on a rack-level would be a more sensible evolution scenario, that could be realized incrementally. For new systems, designing the power architecture in DC also allows to challenge the standard $n+n$ configuration while maintaining a similar reliability while reducing the installation costs, and increasing the overall efficiency and PUE, resulting in a reduction of Operational Expenditure (OPEX).

4.4 Buildings

In complement to what was presented in 2.4, a DC distribution in commercial and industrial buildings represents a significant opportunity for DC systems to develop. A major advantage exists when it comes to modularity. In fact, a DC microgrid could be designed independently of upstream AC network. For example, a tertiary building could present a backbone 700 VDC feeders that will connect 350 VDC blocs that includes very low DC voltage distribution such as USB-C terminals. It could be then modified or reorganized easily without specific technical skills. This new experience brings flexibility in case of rented spaces that requires constant interior adjustment. Apart from that, other main advantages are highlighted in the following.

4.4.1 Efficiency

As already evoked, a DC environment in buildings could represent a considerable improvement in overall energy efficiency. In this perspective, it is possible to observe some interesting data in the literature.

In terms of DC energy generation, it is possible to observe that the use of PV with a LVDC backbone could represent a gain of 8% [31] up to 13% [80] in the efficiency of the distribution system. On the other side, regarding energy consumption, once again interesting conclusions can be highlighted. In [81], the authors show that in 2015 at least 50% of all loads in commercial buildings are DC-compatible and [33] show a 14% loss reduction with the mutualization of several AC/DC conversion steps associated to electronic devices.

Other comparative studies also show that DC powered buildings can be ahead classic ones in terms of efficiency. Table 1 show the main conclusions.

Table 4-1: Efficiency analysis of LVDC buildings

Reference	[82]	[83]	[84]	[85]
Conclusion	For commercial buildings the study shows an improvement of 10 to 11% in energy efficiency	It highlights an overall efficiency improvement of the system of 5.5% and improvement in PV energy use of 7%	For an average commercial building, the energy efficiency improvement is estimated in 9.9 to 11.9%	One of the main conclusions is the reduction in energy consumption associated of 10% to the use of 48V DC loads

It is possible to observe that the association of PV, storage assets and a LVDC backbone in commercial and industrial buildings could be an interesting mix to maximize energy efficiency. The more local DC energy generation is available, the more efficiency improvements would be possible.

4.4.2 Controllability

An additional feature comes from this separation between AC and DC grids. While voltage and frequency are fixed at AC side, DC voltage could be controlled independently to reflect local energy balance. For example, when PV generation is high, the DC voltage of the common busbar will increase spontaneously which will indicate to the loads and storage system the availability of local power. Contrarily, when PV generation is low, the DC voltage of the common busbar will drop giving a signal to the loads that they will consume mainly from the AC grid. The building operator could choose to limit in this case the consumption to the critical loads. This intrinsic control through the voltage would provide a simple and secured management of the building. This type of droop-control based technique proposed by Current/OS Foundation [86], has been proven to be simple, robust and does not need any type of complex communication system, which could represent a reliability issue. Figure below shows an illustration of this concept.

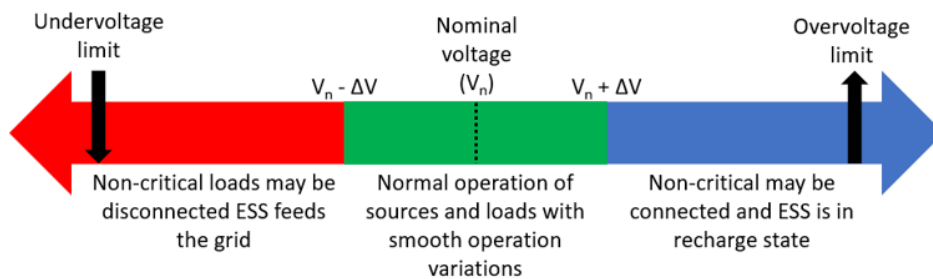

Figure 4-2: decentralized control principle of LVDC distribution grid [87].

4.4.3 Resiliency

Utilizing LVDC for electricity distribution within buildings or clusters offers several significant advantages, one of which is the simplified integration and parallelization of power sources. Unlike AC systems, LVDC operates with a fundamental frequency of zero, eliminating the need for phase synchronization. This facilitates the integration of renewable energy sources and storage assets, as well as real-time grid adjustments to match consumption needs or recover from faults. In a nutshell, DC buildings with on-site energy storage are much less dependent on the AC grid congestions and outages. Moreover, current level of power electronic technology allows DC building to be grid-interactive prosumers capable of providing ancillary services to the grid, from flexibility to phase current balancing in rural feeders.

Furthermore, LVDC infrastructure can support a bipolar distribution architecture, utilizing the same triple-conductor setup as AC systems. This configuration allows for independent management of two DC poles, ensuring continued operation even in the event of a fault or operational issue on one pole.

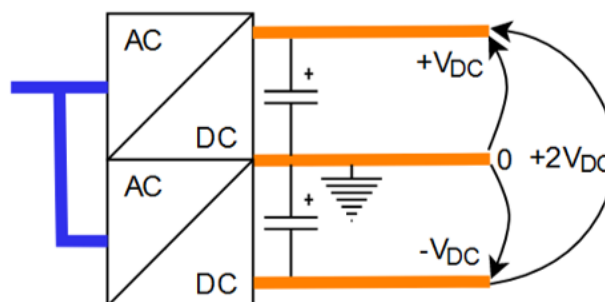

Figure 4-3: Example of bipolar configuration in LVDC distribution grid [87].

Moreover, LVDC overcomes synchronization challenges encountered in ring-based grid topologies, enhancing system resilience and availability by enabling multiple feeding paths to consumers. Various studies [88] have advocated for the adoption of LVDC architecture in future smart grids, alongside tailored protection strategies to optimize performance. For applications requiring maximal availability, LVDC can support meshed distribution grids, offering better power quality and robustness against disruptions.

4.4.4 Perspectives

Even if the use of DC in buildings is a potential driver for renewable energy integration, energy efficiency improvements, better controllability and resiliency, the technology around the domain is still expensive compared to AC. However, in a retroactive loop, the more these systems are deployed around the world because of their benefits, the less expensive DC assets will get (PV, storage, etc.), and the other way around.

Power electronics in general, which is crucial for LVDC distributions systems, is also a domain which is constantly improving (reliability, cost, efficiency, etc.). Highly performant converters, protection devices and controlling devices will soon become economically affordable for LVDC powered buildings.

Furthermore, considering that in LVDC local efficiency, local generation and direct DC-consumption are among the main drivers for the deployment of LVDC distribution systems, its use in commercial, residential, and industrial buildings could represent an important starting point for the global development of this type of solution in distribution grids.

Moreover, based on the state of the art, it is possible to see that the technology necessary to make LVDC-powered buildings exists, as well as the motivation to do it. The increasing number of different actors and ecosystems in Europe and around the world is a concrete proof of that.

Finally, individual LVDC distribution systems may evolve and be interconnected, forming a cluster, which could have a ring-based or meshed architecture. It would represent a highly controllable, resilient, and energy efficient structure for high self-consumption.

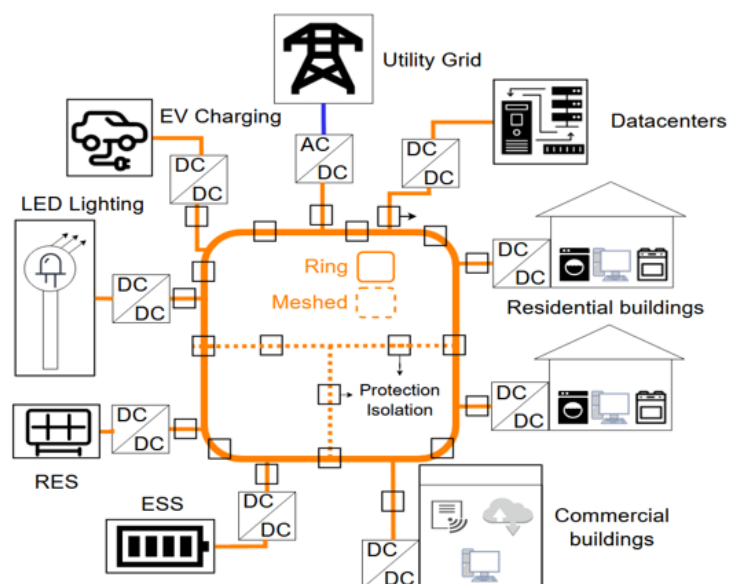

Figure 4-4: future ring/meshed LVDC distribution cluster [87].

4.5 MVDC and LVDC Grids

Despite the challenges outlined in Chapter 3, MVDC and LVDC grids offer numerous advantages, beyond just efficiency gains, which pave the way for various opportunities and evolution scenarios. These advantages include [89]:

- Enhanced electrical safety and a platform for smart monitoring, demand management, and automated network control compared to equivalent AC systems.
- Substantial reduction in supply security investment costs mandated by electricity market regulations, resulting in lower life-cycle costs.
- Facilitation of island mode activation and provision of high supply security when resources are available.
- Increased controllability of distribution systems through ready-to-use hardware for local reactive power and voltage control without requiring additional investments.
- Ensure controlled high-quality supply voltage for customers' appliances and an easy-to-control connection point for small-scale generation units and storages.

Several opportunities and evolution scenarios for MVDC and LVDC technologies are presented, with a focus on the upcoming years. These scenarios, often referred to as roadmaps, are guided by leading entities in the sector, such as the European Commission and ENTSO-E.

4.5.1 MVDC Grids

According to the European Commission Implementation Plan on HVDC and DC Technologies, published in 2021, the transmission grid employs both HVAC and HVDC technologies, whereas the distribution grid relies solely on MVAC. This preference is attributed to the simplicity, effectiveness, and efficiency of the transformers required for voltage step-up or step-down operations. Similarly to HVDC, advancements in high voltage and high-current Power Electronics (PE) devices have facilitated the development of sophisticated high-power electronic converters capable of performing AC/DC voltage conversion within the MV range with significantly high efficiencies.

The significant aspect of an MVDC grid lies in its innovative infrastructure, which aims at facilitating potential applications. Today, with the possibility of connecting renewables such as PV or wind farms directly to MVDC grids instead of converting to AC, the MVDC distribution grid has become an area of interest for grid optimization. Furthermore, segmenting MVAC grids into sections with DC could offer several advantages to Distribution System Operators (DSOs) by enhancing the flexibility and controllability of distribution systems. This is increasingly important as distribution systems are required to act as active grids, rather than passive ones as in the past, due to the continuously rising penetration levels of Distributed Generation and RES in medium voltage systems.

Moreover, with the liberalization of the electrical energy market, cross-border exchange of electricity could be executed at the MVDC level, eliminating the need to step-up the MV to HV across borders and then step it back down to MV again. In this context, MVDC grids have the potential to reduce the number of energy conversion stages required on both the supply and load sides, thereby simplifying the overall electrical architecture. Consequently, the distribution of electricity would not only be achieved with higher efficiency and reliability but also with increased control flexibility. This streamlined approach to cross-border electricity exchange can enhance grid stability and resilience while facilitating seamless integration of renewable energy sources and distributed generation.

MVDC networks present the opportunity to "mesh" the existing MVAC distribution network, enhancing its robustness and controllability. This facilitates the decoupling of AC sections and enables the

seamless integration of RES at the distribution level. As MVDC networks evolve towards multiterminal configurations, it becomes imperative to implement appropriate fault protection strategies. These strategies include fault detection and location identification methods, as well as selectivity logics for fault suppression. By deploying effective fault protection mechanisms, MVDC networks can ensure reliable operation while maximizing the utilization of renewable energy resources, contributing to a more sustainable and resilient electrical infrastructure.

Therefore, the deployment of efficient solid-state circuit breakers and the development of breakerless protection approaches based on fully controlled power converters with inherent fault current limiting capabilities are considered crucial challenges. Additionally, suitable standardization efforts are essential to ensure interoperability and compatibility across MVDC networks. Furthermore, the development of new highly efficient DC/DC and DC/AC converters, leveraging wide band gap material-based devices, is seen as an important technological challenge in the short term. These advancements will play a vital role in enhancing the performance and reliability of MVDC systems, paving the way for their widespread adoption and integration into modern power grids.

The H2020 Project TIGON, spanning from September 2020 to August 2024, is currently focused on advancing several MVDC technologies ranging from TRL 5 to 7 and 8 [90]. These technologies include the development of a Solid-State Transformer, MVDC multi-terminal grid, and MVDC-connected PV plant and BESS. Additionally, TIGON is working on Wide Area Monitoring Protection and Control (WAMPAC) and Energy Management System (EMS) systems to stabilize and control the DC grid effectively. The TIGON solution aims to enhance the original energy efficiency of the systems by at least an additional 25%, primarily through savings in conversion processes. This project is poised to play a significant role in advancing MVDC technologies and contributing to the efficiency and stability of future power grids.

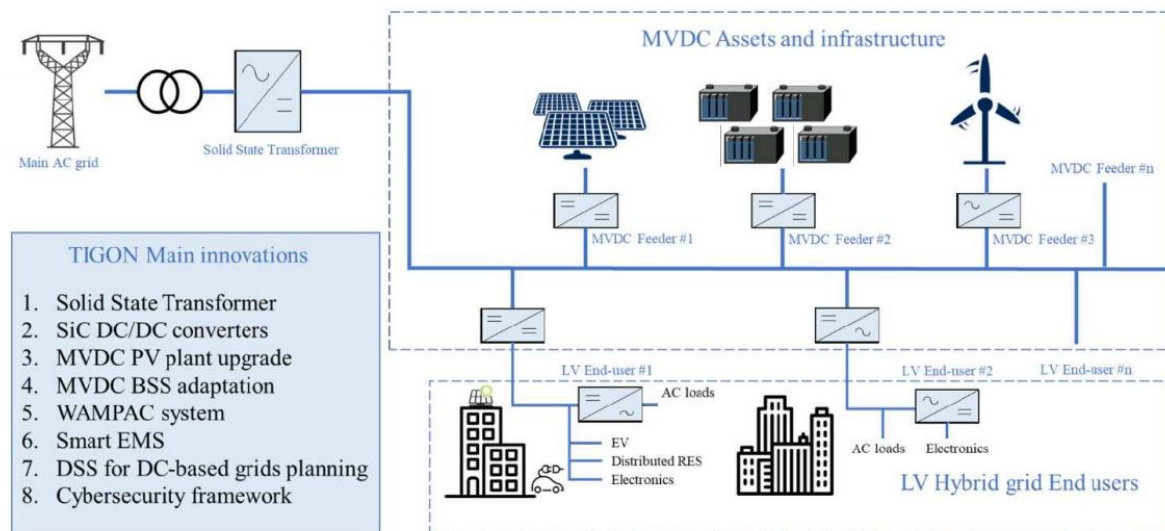

Figure 4-5: Project TIGON vision for MVDC and LVDC distribution deployment [90].

4.5.2 LVDC Grids

For LVDC, unlike HVDC or MVDC, the emphasis is primarily on operational efficiency rather than technological complexity. Unlike their HV counterparts, LVDC systems in principle do not require specialized circuit breakers or specific cable insulations, as their insulation requirements are less demanding, and LVDC equipment is generally simpler [34].

The current project SHIFT2DC indeed has the objective of demonstrating this regarding cables. PV string cables are used with high constraints: outside, with different climate conditions, the cable industry has

defined a standard at European level (EN 50 618) to answer the demand. However, the Return of Experiment done shows that there are still challenges to fulfil: Full water immersion of the cables, hot conditions, variable installation rules, high electrical stress in the cables. That is the reason why there are still R&D activities to define the best solution that combines all these criteria [91], [92].

As illustrated in Figure 4-6 below, there are already existing LVDC applications, and LVDC distribution grids are considered an emerging technology with significant potential for future deployment.

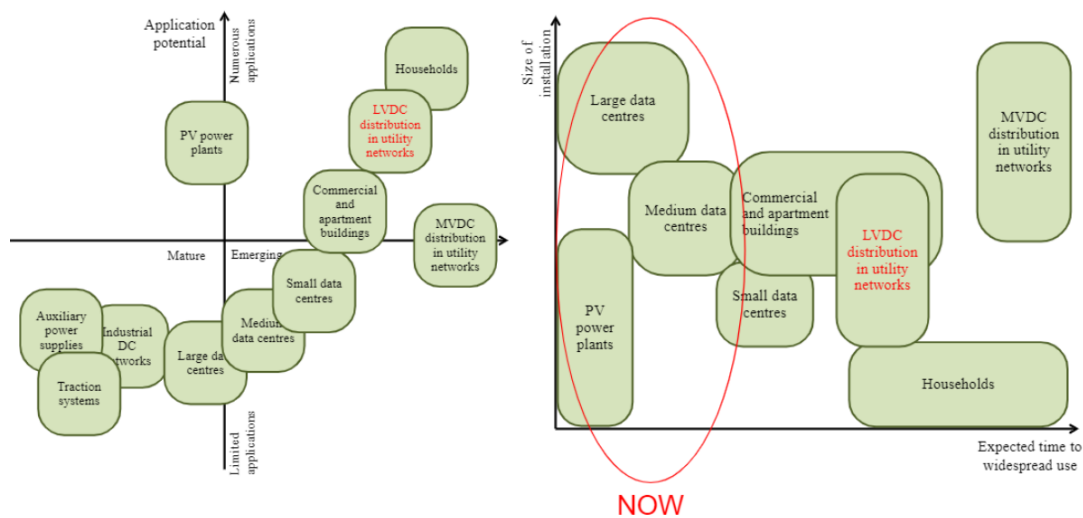

Figure 4-6: LVDC technology roadmap [89].

In the near future, the primary LVDC technological advancements are closely linked to wide band gap material-based devices, such as SiC and GaN. These materials offer significantly higher converter operating frequencies and efficiency, resulting in substantial savings in size, weight, and materials. For instance, new configurations of DC-DC converters utilizing SiC technology and resonant circuits are projected to achieve energy efficiencies exceeding 98% [90]. In contrast, typical LV AC/DC converters typically exhibit efficiencies ranging from 75% to 90%, while inverters generally range from 90% to 95%. This implies that by avoiding conversion to AC and back to DC for consumption, the efficiency of DC-generated power can be increased up to approximately 25%.

4.5.3 Cables

The actual knowledge of technologies, the actual quick and strong evolution on the limitation of usage of natural material is a big opportunity to design DC cables integrating all this new knowledge. One important question is if the carbon footprint of cables can be reduced significantly due to their operation under DC. The Life Cycle Assessment comparison could be a tool to help to answer to the question.

DC network, DC usage for a lot of electronic, lighting usages will help to reduce the energy consumption. That means that, globally, the energy to transfer through the cables will be reduced. That is a good opportunity to create new design with downsizing the designs. Association of new technologies, modern industrial capability will allow to progress in this direction.

As long as LVDC cables are a key element in electrical infrastructures aiming to interface load and sources, prior knowledge of the system configuration (unipolar or bipolar), and results from steady states, short-circuit and stability studies are determining factor when defining the appropriate cables for the installation.

In addition, the active parameters of the cable (R, L and C), the cross section and the cable length influence the behaviour of the system and could contribute to support the network [93]. LVDC cable parameter could contribute to improving the performance of the network by reducing oscillation, getting higher system protection and improving stability.

5 Conclusions

5.1 Summary

This deliverable presented the results of Task 1.1 – “DC Applications, Challenges, Opportunities and Evolution Scenarios” of Project SHIFT2DC.

In the first chapter, the current and prospective applications of Direct Current technology were discussed. Five main types of applications were identified, based on the objectives of the Project and the research topics of the Project Partners: Industry, Ports, Data Centres, Buildings and Grids. For each type of Application, the main types of DC equipment and their advantages were described. The main conclusion across all types of applications is that much of the loads (e.g. drives, motors, electronics, computers, lightning, EVs, etc.) and RES generation and flexibility assets (e.g. PV, BESS) are already working in DC, so connecting them through AC requires two conversion steps and associated efficiency losses, which can be avoided by using DC. Also, all applications are energy intensive and conversion to DC has a large impact and can uncover many use cases and innovations, especially in cases where grid connection capacity is already being a problem in AC.

Nevertheless, widespread adoption of DC technology in LVDC and MVDC applications poses significant challenges that must be addressed, and thus are a significant point in the SHIFT2DC project. On Technological challenges, several issues were identified that need to be object of work to enable DC adoption, such as: circuit breakers, cables, protections, and control and operation of a DC system. On Economical, Standardization and Regulatory Challenges, the general conclusion is that there is still a great lacking in standardization and regulation regarding LVDC and MVDC, but this will be analysed in further detail in a specific deliverable of this project (D1.2). On Stakeholder acceptance, it was concluded that DC technology can be easily accepted if some factors like energy costs, productivity, quality of life are improved. Nevertheless, some studies demonstrated that easiness of use is key for the Acceptance, so DC technology should be at least, as easy to deal with as AC. Finally, in the Eco-systems challenges subsection, the conclusion was that initiatives like Current/OS Foundation and the Open DC Alliance (ODCA) are essential to promote the development and adoption of DC solutions worldwide, in a seamless and sustainable way.

Having described and analysed the DC Applications and Challenges, the final section of this document delved in the enormous Opportunities and the respective Evolution Scenarios that come with the future adoption of DC technology. The main benefits come from an overall efficiency increase in the system, that is related with the absence of AC/DC conversion losses, reactive power losses, and copper losses due to higher operating voltages that can be used for the same insulation. The energy transition goals are very demanding on electrification of the society, and in some cases the electrification rate is already very close to the limit without the adoption of disruptive efficiency improving technologies like DC. For buildings and data centres, other productivity and quality improvement opportunities like increased digitalization, controllability, resilience, reliability, and sustainability, can come from the adoption of LVDC and MVDC. Finally, for Grids, where HVDC has already a very established market, which is growing at the cost of HVAC, MVDC is still not widespread, but some roadmaps for its development are already established.

5.2 Progress

Being the first technical deliverable of the project, it had the important mission of setting the baseline of knowledge and state-of-the-art of DC technology. Accomplishing this, means that significant progress has been made towards achieving the project's goals. Together the next deliverable D1.2 Policies, Regulatory framework, and Market Architecture for DC solutions, the Challenges, Opportunities and Evolution Scenarios of the different DC applications will be crucial to define the project Use Cases in Task 1.3, and thus to contribute to the overall progress of the Project.

The deliverable, and the Task that originated the document, was also successful in capitalizing the first working collaboration among most of the partners in the project, and also in the fulfilment of the demanding Task and deliverable timelines.

5.3 Main Challenges

The tight timeline of this Task, and the large number of partners with different backgrounds posed a challenge in the production of this deliverable with the quality and content that was required, in the specified deadline.

The Task itself involved the presentation of Challenges related with application of DC in Low and Medium voltage applications. The Challenges are complex and involve Economical, Technical, Regulatory, Standardization, Acceptance and Eco-systems. Almost all of these will have to be addressed throughout the project SHIFT2DC, so the fact that they are described so early in the project was paramount.

Despite of this, the deliverable achieved the proposed objectives, contributing strongly as the first step towards the project goals.

5.4 Next deliverables

As mentioned earlier, the work and results of this deliverable, and the Task that led its preparation, will continue, and feed the next deliverables from WP1 - "DC Solutions: Use Cases, Policies, Barriers, Opportunities and Social Adoption", which are:

- D1.2 Policies, Regulatory framework, and Market Architecture for DC solutions
- D1.3 Use Case Repository
- D1.4 Specification of DC solutions, tools and devices

6 References

- [1] B. A. Thomas, I. L. Azevedo, and G. Morgan, “Edison Revisited: Should we use DC circuits for lighting in commercial buildings?,” *Energy Policy*, vol. 45, pp. 399–411, Jun. 2012, doi: 10.1016/j.enpol.2012.02.048.
- [2] S. Khan, K. Rahman, M. Tariq, S. Hameed, B. Alamri, and T. S. Babu, “Solid-State Transformers: Fundamentals, Topologies, Applications, and Future Challenges,” *Sustainability*, vol. 14, no. 1, p. 319, Dec. 2021, doi: 10.3390/su14010319.
- [3] Schaltbau, “Neuer Standard für eine grüne Produktion: Weltweit erste Gleichstromfabrik geht in den Betrieb.” Accessed: Mar. 14, 2024. [Online]. Available: <https://www.schaltbau.com/de/unternehmen/nachhaltigkeit/next-factory/schaltbau-eroeffnet-next-factory-in-velden/>
- [4] BMW Group, “AC wird zu DC.” Accessed: Mar. 08, 2024. [Online]. Available: <https://www.bmwgroup.com/de/news/allgemein/2020/ac-dc.html>
- [5] European Commission, “Fourth Annual Report from the European Commission on CO2 Emissions from Maritime Transport (period 2018-2021).” 2023. Accessed: Feb. 18, 2024. [Online]. Available: https://climate.ec.europa.eu/document/download/e3ddba7a-c068-4f87-a7c2-e98d63e56cf0_en?filename=swd_2023_54_en.pdf
- [6] European Commission, “Reducing emissions from the shipping sector.” 2023. Accessed: Feb. 18, 2024. [Online]. Available: https://climate.ec.europa.eu/eu-action/transport/reducing-emissions-shipping-sector_en
- [7] *FuelEU Maritime regulation*. Accessed: Feb. 18, 2024. [Online]. Available: <https://eur-lex.europa.eu/legal-content/EN/TXT/HTML/?uri=CELEX:52021PC0562>
- [8] International Council on Clean Transportation, “Shore power needs and CO2 emissions reductions of ships in European Union ports: Meeting the ambitions of the FuelEU Maritime and AFIR.” 2023. Accessed: Feb. 18, 2024. [Online]. Available: <https://theicct.org/wp-content/uploads/2023/10/Shore-power-ships-EU-Fit-for-55-working-paper-24-v3.pdf>
- [9] EMSA, “Shore-Side Electricity, Guidance to Port Authorities and Administrations - Part 1 – Equipment and Technology,” Jun. 2022. [Online]. Available: <https://www.emsa.europa.eu/electrification/sse.html>
- [10] R. Glavinović, M. Krčum, L. Vukić, and I. Karin, “Cold Ironing Implementation Overview in European Ports—Case Study—Croatian Ports,” *Sustainability*, vol. 15, no. 11, p. 8472, May 2023, doi: 10.3390/su15118472.
- [11] N. N. Abu Bakar, N. Bazmohammadi, J. C. Vasquez, and J. M. Guerrero, “Electrification of onshore power systems in maritime transportation towards decarbonization of ports: A review of the cold ironing technology,” *Renew. Sustain. Energy Rev.*, vol. 178, p. 113243, May 2023, doi: 10.1016/j.rser.2023.113243.
- [12] S. Fang, Y. Wang, B. Gou, and Y. Xu, “Toward Future Green Maritime Transportation: An Overview of Seaport Microgrids and All-Electric Ships,” *IEEE Trans. Veh. Technol.*, vol. 69, no. 1, pp. 207–219, Jan. 2020, doi: 10.1109/TVT.2019.2950538.
- [13] S. Karimi, M. Zadeh, and J. A. Suul, “Shore Charging for Plug-In Battery-Powered Ships: Power System Architecture, Infrastructure, and Control,” *IEEE Electrification Mag.*, vol. 8, no. 3, pp. 47–61, Sep. 2020, doi: 10.1109/MELE.2020.3005699.
- [14] Safety4Sea, “Cold Ironing: The role of ports in reducing shipping emissions,” *Green Shipping, Maritime Knowledge, Ports*, 2019. Accessed: Feb. 19, 2024. [Online]. Available: <https://safety4sea.com/cm-cold-ironing-the-role-of-ports-in-reducing-shipping-emissions/>
- [15] M. Parhamfar, I. Sadeghkhanjani, and A. M. Adeli, “Towards the application of renewable energy technologies in green ports: Technical and economic perspectives,” *IET Renew. Power Gener.*, vol. 17, no. 12, pp. 3120–3132, Sep. 2023, doi: 10.1049/rpg2.12811.

- [16] A. Buonomano, G. Del Papa, G. F. Giuzio, A. Palombo, and G. Russo, "Future pathways for decarbonization and energy efficiency of ports: Modelling and optimization as sustainable energy hubs," *J. Clean. Prod.*, vol. 420, p. 138389, Sep. 2023, doi: 10.1016/j.jclepro.2023.138389.
- [17] F. D. Kanellos, G. J. Tsekouras, V. C. Nikolaidis, and J. M. Prousalidis, "Toward Smart Green Seaports: What should be done to transform seaports into intelligent and environment-friendly energy systems?," *IEEE Electrification Mag.*, vol. 11, no. 1, pp. 33–42, Mar. 2023, doi: 10.1109/MELE.2022.3232980.
- [18] A. Vujičić, N. Zrnić, and B. Jerman, "Ports Sustainability: A life cycle assessment of Zero Emission Cargo Handling Equipment," *Stroj. Vestn. – J. Mech. Eng.*, vol. 9, no. 59, pp. 547–555, Sep. 2013, doi: 10.5545/sv-jme.2012.933.
- [19] N. B. B. Ahamad, C.-L. Su, X. Zhaoxia, J. C. Vasquez, J. M. Guerrero, and C.-H. Liao, "Energy Harvesting From Harbor Cranes With Flywheel Energy Storage Systems," *IEEE Trans. Ind. Appl.*, vol. 55, no. 4, pp. 3354–3364, Jul. 2019, doi: 10.1109/TIA.2019.2910495.
- [20] G. Parise, L. Parise, A. Malerba, F. M. Pepe, A. Honorati, and P. B. Chavdarian, "Comprehensive Peak-Shaving Solutions for Port Cranes," *IEEE Trans. Ind. Appl.*, vol. 53, no. 3, pp. 1799–1806, May 2017, doi: 10.1109/TIA.2016.2645514.
- [21] Y. Peng, H. Liu, X. Li, J. Huang, and W. Wang, "Machine learning method for energy consumption prediction of ships in port considering green ports," *J. Clean. Prod.*, vol. 264, p. 121564, Aug. 2020, doi: 10.1016/j.jclepro.2020.121564.
- [22] S. Badakhshan, S. Senemmar, and J. Zhang, "Dynamic Feasibility Assessment of Ship-to-Grid Interconnection by DC-Link," in *2022 IEEE Texas Power and Energy Conference (TPEC)*, College Station, TX, USA: IEEE, Feb. 2022, pp. 1–6. doi: 10.1109/TPEC54980.2022.9750767.
- [23] N. N. A. Bakar *et al.*, "Optimal Configuration and Sizing of Seaport Microgrids including Renewable Energy and Cold Ironing—The Port of Aalborg Case Study," *Energies*, vol. 15, no. 2, p. 431, Jan. 2022, doi: 10.3390/en15020431.
- [24] Committee on Enhancing the Resilience of the Nation's Electric Power Transmission and Distribution System, Board on Energy and Environmental Systems, Division on Engineering and Physical Sciences, and National Academies of Sciences, Engineering, and Medicine, *Enhancing the Resilience of the Nation's Electricity System*. Washington, D.C.: National Academies Press, 2017, p. 24836. doi: 10.17226/24836.
- [25] A. Rolan, P. Manteca, R. Oktar, and P. Siano, "Integration of Cold Ironing and Renewable Sources in the Barcelona Smart Port," *IEEE Trans. Ind. Appl.*, vol. 55, no. 6, pp. 7198–7206, Nov. 2019, doi: 10.1109/TIA.2019.2910781.
- [26] A. Buonomano, G. Del Papa, G. F. Giuzio, A. Palombo, and G. Russo, "Future pathways for decarbonization and energy efficiency of ports: Modelling and optimization as sustainable energy hubs," *J. Clean. Prod.*, vol. 420, p. 138389, Sep. 2023, doi: 10.1016/j.jclepro.2023.138389.
- [27] D. Pivetta, C. Dall'Armi, P. Sandrin, M. Bogar, and R. Tacconi, "The role of hydrogen as enabler of industrial port area decarbonization," *Renew. Sustain. Energy Rev.*, vol. 189, p. 113912, Jan. 2024, doi: 10.1016/j.rser.2023.113912.
- [28] European Commission. Directorate General for Communications Networks, Content and Technology., Environment Agency Austria., Borderstep Institute, and Umweltbundesamt., *Energy-efficient cloud computing technologies and policies for an eco-friendly cloud market: final study report*. LU: Publications Office, 2020. Accessed: Feb. 20, 2024. [Online]. Available: <https://data.europa.eu/doi/10.2759/3320>
- [29] J. Davis, D. Bizo, A. Lawrence, O. Rogers, and M. Smolaks, "Uptime Institute Global Data Center Survey 2022." Uptime Institute.
- [30] European C, "Energy Performance of Buildings Directive."
- [31] D. Fregosi *et al.*, "A comparative study of DC and AC microgrids in commercial buildings across different climates and operating profiles," in *2015 IEEE First International Conference on DC*

- Microgrids (ICDCM)*, Atlanta, GA, USA: IEEE, Jun. 2015, pp. 159–164. doi: 10.1109/ICDCM.2015.7152031.
- [32] A. Alsaedi, F. Alharbi, A. Alahdal, Ahmed. N. M. Alahmadi, A. Ammous, and K. Ammous, “Low Voltage Direct Current Supplies Concept for Residential Applications,” *Energy Explor. Exploit.*, vol. 40, no. 3, pp. 1078–1097, May 2022, doi: 10.1177/01445987211072893.
- [33] K. Garbesi, V. Vossos, and H. Shen, “Catalog of DC Appliances and Power Systems,” Energy Analysis Department Environmental Energy Technologies Division Lawrence Berkeley National Laboratory, 2011.
- [34] Y. Liang, “Medium Voltage DC Distribution Systems,” CIGRE.
- [35] J. Hu, S. Cui, and R. W. De Doncker, “DC Fault Ride-Through of a Three-Phase Dual-Active Bridge Converter for DC Grids,” in *2018 International Power Electronics Conference (IPEC-Niigata 2018 - ECCE Asia)*, Niigata: IEEE, May 2018, pp. 2250–2256. doi: 10.23919/IPEC.2018.8507672.
- [36] European Standards, “BS EN 50122-2:2022 - Railway applications. Fixed installations. Electrical safety, earthing and the return circuit Provisions against the effects of stray currents caused by DC traction systems.” Jan. 11, 2023. Accessed: Mar. 27, 2024. [Online]. Available: <https://www.en-standard.eu/bs-en-50122-2-2022-railway-applications-fixed-installations-electrical-safety-earthing-and-the-return-circuit-provisions-against-the-effects-of-stray-currents-caused-by-dc-traction-systems/>
- [37] European Standards, “BS EN 12954:2019 - General principles of cathodic protection of buried or immersed onshore metallic structures.” Aug. 29, 2019. Accessed: Mar. 27, 2024. [Online]. Available: <https://www.en-standard.eu/bs-en-12954-2019-general-principles-of-cathodic-protection-of-buried-or-immersed-onshore-metallic-structures/>
- [38] C. Gu, P. Wheeler, A. Castellazzi, A. J. Watson, and F. Effah, “Semiconductor Devices in Solid-State/Hybrid Circuit Breakers: Current Status and Future Trends,” *Energies*, vol. 10, no. 4, p. 495, Apr. 2017, doi: 10.3390/en10040495.
- [39] K. Askan, M. Bartonek, and K. Weichselbaum, “Power Module for Low Voltage DC Hybrid Circuit Breaker,” presented at the 2019 IEEE Third International Conference on DC Microgrids (ICDCM), Matsue, Japan: IEEE, May 2019. doi: 10.1109/ICDCM45535.2019.9232874.
- [40] “Current Router,” <http://www.dc.systems/>. Accessed: Mar. 04, 2024. [Online]. Available: <https://www.dc.systems/assets/public/Datasheet-Current-Router.pdf>
- [41] “VARC — Experimental Verification,” scibreak.com. [Online]. Available: <https://scibreak.com/technology/experimental-work/>
- [42] EATON, “Eaton backs ground-breaking HYPERRIDE joint research into DC grids.” Accessed: Mar. 13, 2024. [Online]. Available: <https://www.eaton.com/gb/en-gb/company/news-insights/news-releases/2020/hyperride-project-dc-grids.html>
- [43] A. Qawasmi, J. Teichrib, N. Venkatesh, and R. W. de Donker, “A New Thyristor-Based Power Electronic Device for DC Circuit Breakers in Medium-Voltage Applications,” in *2018 9th IEEE International Symposium on Power Electronics for Distributed Generation Systems (PEDG)*, Charlotte, NC, USA: IEEE, Jun. 2018. doi: 10.1109/PEDG.2018.8447700.
- [44] J. Warmuz, A. A. T. Khan, A. Qawasmi, and R. W. de Donker, “Diode-Assisted Gate-Commutated Thyristor for Hybrid MVDC Circuit Breaker Applications,” vol. IEEE journal of emerging and selected topics in power electronics, no. 11, pp. 2697–2706, 2023, doi: 10.1109/JESTPE.2022.3232839.
- [45] K. Fuchs, F. Berger, D. Schaffrinna, and R. Apel, “Thermal-electrical aging of selected polymeric LVAC cables under DC voltage stress,” presented at the 10 th International Conference on Insulated Power Cables, Paris-Versailles/France, Jun. 2019.
- [46] Open DC Alliance, “System concept for DC-INDUSTRIE2,” Jul. 2023. [Online]. Available: <https://dc-industrie.zvei.org/en/publications/system-concept-for-dc-industrie2>
- [47] “openADR alliance.” [Online]. Available: <https://www.openadr.org/>

- [48] “OPEN STANDARDS FOR THE DISTRIBUTED ENERGY INDUSTRY.” [Online]. Available: <https://sunspec.org/>
- [49] Z. Pató, “Gridlock in the Netherlands,” Regulatory Assistance Project, Feb. 2024. [Online]. Available: <https://www.raponline.org/knowledge-center/gridlock-in-netherlands/>
- [50] International Energy Agency, “Energy system of The Netherlands.” Accessed: Mar. 08, 2024. [Online]. Available: <https://www.iea.org/countries/the-netherlands>
- [51] A. Eales, L. Walley, H. Buckland, D. Frame, and S. Strachan, “Social Impacts of Mini-Grids: Towards an Evaluation Methodology,” in *2018 IEEE PES/IAS PowerAfrica*, Jun. 2018, pp. 354–359. doi: 10.1109/PowerAfrica.2018.8521049.
- [52] A. López-González, B. Domenech, and L. Ferrer-Martí, “Sustainability and design assessment of rural hybrid microgrids in Venezuela,” *Energy*, vol. 159, pp. 229–242, Sep. 2018, doi: 10.1016/j.energy.2018.06.165.
- [53] F. Antonanzas-Torres, J. Antonanzas, and J. Blanco-Fernandez, “State-of-the-Art of Mini Grids for Rural Electrification in West Africa,” *Energies*, vol. 14, no. 4, Art. no. 4, Jan. 2021, doi: 10.3390/en14040990.
- [54] R. Madlener, C. Flath, and C. van Dinther, “Priorities in smart grid design research,” *PLOS Clim.*, vol. 2, no. 8, p. e0000262, Aug. 2023, doi: 10.1371/journal.pclm.0000262.
- [55] Harm de Been, “The acceptance of direct current (DC) electricity in Dutch households | The influence of framing and social proof on the acceptance of a DC house,” MSc, Leiden University, Leiden, The Netherlands, 2016. Accessed: Feb. 19, 2024. [Online]. Available: <https://staff-studenttheses.universiteitleiden.nl/access/item%3A2628382/view>
- [56] B. Glasgo, I. L. Azevedo, and C. Hendrickson, “Expert assessments on the future of direct current in buildings,” *Environ. Res. Lett.*, vol. 13, no. 7, p. 074004, Jun. 2018, doi: 10.1088/1748-9326/aaca42.
- [57] U. C. Bandara and T. S. M. Amarasena, “Impact of Relative Advantage, Perceived Behavioural Control and Perceived Ease of Use on Intention to Adopt with Solar Energy Technology in Sri Lanka,” in *2018 International Conference and Utility Exhibition on Green Energy for Sustainable Development (ICUE)*, Oct. 2018, pp. 1–9. doi: 10.23919/ICUE-GESD.2018.8635706.
- [58] V. Vossos *et al.*, “Adoption Pathways for DC Power Distribution in Buildings,” *Energies*, vol. 15, no. 3, Art. no. 3, Jan. 2022, doi: 10.3390/en15030786.
- [59] C.-W. Chang and W. H. Hung, “Key factors of adopting energy management systems in building sector in Taiwan,” in *ICEB 2022 Proceedings (Bangkok, Thailand)*, Bangkok, Thailand: AIS eLibrary, 2022. [Online]. Available: <https://aisel.aisnet.org/iceb2022/27>
- [60] F. D. Davis, “Perceived Usefulness, Perceived Ease of Use, and User Acceptance of Information Technology,” *MIS Q.*, vol. 13, no. 3, pp. 319–340, 1989, doi: 10.2307/249008.
- [61] A. Mehrabian and J. A. Russell, *An approach to environmental psychology*. in An approach to environmental psychology. Cambridge, MA, US: The MIT Press, 1974, pp. xii, 266.
- [62] V. Venkatesh, M. G. Morris, G. B. Davis, and F. D. Davis, “User Acceptance of Information Technology: Toward a Unified View,” *MIS Q.*, vol. 27, no. 3, pp. 425–478, 2003, doi: 10.2307/30036540.
- [63] S. Kulviwat, G. C. Bruner Ii, A. Kumar, S. A. Nasco, and T. Clark, “Toward a unified theory of consumer acceptance technology,” *Psychol. Mark.*, vol. 24, no. 12, pp. 1059–1084, Dec. 2007, doi: 10.1002/mar.20196.
- [64] S. FakhrHosseini *et al.*, “User Adoption of Intelligent Environments: A Review of Technology Adoption Models, Challenges, and Prospects,” *Int. J. Human–Computer Interact.*, vol. 40, no. 4, pp. 986–998, Feb. 2024, doi: 10.1080/10447318.2022.2118851.
- [65] V. Rai, “Expert elicitation methods for studying technological change under uncertainty,” *Environ. Res. Lett.*, vol. 8, no. 4, p. 041003, Oct. 2013, doi: 10.1088/1748-9326/8/4/041003.
- [66] Z. Sardar, “The Namesake: Futures; futures studies; futurology; futuristic; foresight—What’s in a name?,” *Futures*, vol. 42, no. 3, pp. 177–184, Apr. 2010, doi: 10.1016/j.futures.2009.11.001.

- [67] Deutsche Kommission Elektrotechnik (DKE), “Steigerung der Energieeffizienz in Industrie durch Gleichstrom-Nutzung.” Accessed: Mar. 01, 2024. [Online]. Available: <https://www.dke.de/de/arbeitsfelder/core-safety/gleichstrom>
- [68] European Union, “Regulation (EU) No 1315/2013 of the European Parliament and of the Council of 11 December 2013 on Union guidelines for the development of the trans-European transport network and repealing Decision No 661/2010/EU Text with EEA relevance.” 2013. [Online]. Available: <https://eur-lex.europa.eu/legal-content/EN/TXT/?uri=celex:32013R1315>
- [69] European Commission, “Europe’s Seaports 2030: Challenges Ahead,” Mar. 23, 2013. [Online]. Available: https://ec.europa.eu/commission/presscorner/detail/en/MEMO_13_448
- [70] European Commission, “Proposal for a REGULATION OF THE EUROPEAN PARLIAMENT AND OF THE COUNCIL on the deployment of alternative fuels infrastructure, and repealing Directive 2014/94/EU of the European Parliament and of the Council.” 2021. [Online]. Available: <https://eur-lex.europa.eu/legal-content/en/TXT/?uri=CELEX:52021PC0559>
- [71] Q. Zhang, Y. Zeng, Y. Hu, Y. Liu, X. Zhuang, and H. Guo, “Droop-Free Distributed Cooperative Control Framework for Multisource Parallel in Seaport DC Microgrid,” *IEEE Trans. Smart Grid*, vol. 13, no. 6, pp. 4231–4244, Nov. 2022, doi: 10.1109/TSG.2022.3184841.
- [72] EMSA, “Shore-Side Electricity, Guidance to Port Authorities and Administrations - Part 2 – Planning, Operations and Safety,” Aug. 2022. [Online]. Available: <https://www.emsa.europa.eu/electrification/sse.html>
- [73] European Sea Port Organization, “ESPO Environmental Report 2023.” ESPO, Oct. 2023. [Online]. Available: <https://www.espo.be/publications/espo-environmental-report-2023>
- [74] K. M. U. Ahmed, M. H. J. Bollen, and M. Alvarez, “A Review of Data Centers Energy Consumption and Reliability Modeling,” *IEEE Access*, vol. 9, pp. 152536–152563, 2021, doi: 10.1109/ACCESS.2021.3125092.
- [75] J. Klemola, “Efficiency beyond the AC based datacenter designs; 400VDC power feed solutions,” presented at the OCP Summit 2018, San Jose, Mar. 20, 2018. Accessed: Feb. 23, 2024. [Online]. Available: <https://www.opencompute.org/files/OCP18-400VDC-Efficiency-02.pdf>
- [76] P. Fernandez, “Open Rack V2.1 Standard Compliant 48V System Design,” presented at the OCP Summit 2018, San Jose, Mar. 20, 2018. Accessed: Feb. 23, 2024. [Online]. Available: <https://www.opencompute.org/files/OCP18-Workshop-Huawei-v2-final.pdf>
- [77] S. Ci, N. Lin, Y. Zhou, H. Li, and Y. Yang, “A New Digital Power Supply System for Fog and Edge Computing,” in *2018 14th International Wireless Communications & Mobile Computing Conference (IWCMC)*, Limassol, Cyprus: IEEE, Jun. 2018, pp. 1513–1517. doi: 10.1109/IWCMC.2018.8450497.
- [78] K. Hirose, “DC Microgrid for Telecommunications Service and Related Application,” in *2018 International Power Electronics Conference (IPEC-Niigata 2018 -ECCE Asia)*, Niigata: IEEE, May 2018, pp. 593–597. doi: 10.23919/IPEC.2018.8508016.
- [79] Y. Chen, K. Shi, M. Chen, and D. Xu, “Data Center Power Supply Systems: From Grid Edge to Point-of-Load,” *IEEE J. Emerg. Sel. Top. Power Electron.*, vol. 11, no. 3, pp. 2441–2456, Jun. 2023, doi: 10.1109/JESTPE.2022.3229063.
- [80] K. Garbesi, V. Vossos, A. Sanstad, and G. Burch, “Optimizing Energy Savings from Direct-DC in U.S. Residential Buildings,” Environmental Energy Technologies Division Lawrence Berkeley National Laboratory. [Online]. Available: <https://www.osti.gov/biblio/1051847>
- [81] E. Rodriguez-Diaz, M. Savaghebi, J. C. Vasquez, and J. M. Guerrero, “An overview of low voltage DC distribution systems for residential applications,” in *2015 IEEE 5th International Conference on Consumer Electronics - Berlin (ICCE-Berlin)*, Berlin, Germany: IEEE, Sep. 2015, pp. 318–322. doi: 10.1109/ICCE-Berlin.2015.7391268.
- [82] S. Anand and B. G. Fernandes, “Optimal voltage level for DC microgrids,” in *IECON 2010 - 36th Annual Conference on IEEE Industrial Electronics Society*, Glendale, AZ, USA: IEEE, Nov. 2010, pp. 3034–3039. doi: 10.1109/IECON.2010.5674947.

- [83] R. Weiss, L. Ott, and U. Boeke, “Energy efficient low-voltage DC-grids for commercial buildings,” in *2015 IEEE First International Conference on DC Microgrids (ICDCM)*, Atlanta, GA, USA: IEEE, Jun. 2015, pp. 154–158. doi: 10.1109/ICDCM.2015.7152030.
- [84] D. L. Gerber, V. Vossos, W. Feng, A. Khandekar, C. Marnay, and B. Nordman, “A simulation based comparison of AC and DC power distribution networks in buildings,” in *2017 IEEE Second International Conference on DC Microgrids (ICDCM)*, Nuremberg, Germany: IEEE, Jun. 2017, pp. 588–595. doi: 10.1109/ICDCM.2017.8001107.
- [85] L. J. O., R. Chacko, R. R. Eapen, and V. Sankar, “A Study on LVDC Systems for Commercial Building Applications,” in *2022 IEEE 19th India Council International Conference (INDICON)*, Kochi, India: IEEE, Nov. 2022, pp. 1–6. doi: 10.1109/INDICON56171.2022.10039905.
- [86] Current/OS, “The Set of Rules.” Accessed: Mar. 22, 2024. [Online]. Available: <https://currentos.foundation/protocol#the-set-of-rules>
- [87] César Augusto Slongo, “Réseaux de distribution à courant continu/basse tension : analyse du convertisseur CA/CC principal, de la qualité de l’énergie et des protection,” Doctoral thesis, Université de Bordeaux, 2023.
- [88] J. Saat, S. Stein, M. Müllender, and A. Ulbig, “Planning and design of urban low-voltage DC grids,” *Electr. Power Syst. Res.*, vol. 211, p. 108461, Oct. 2022, doi: 10.1016/j.epsr.2022.108461.
- [89] T. Kaipia, T. Suntio, and T. Rauhala, “LVDC and Power Electronics Enabling Technologies. Roadmap 2025,” presented at the Technology Workshop, Lappeenranta: LUT, 2015.
- [90] TIGON, “Demonstrating hybrid microgrid innovations for greener, more resilient and more secure power networks,” EU-funded innovation project. [Online]. Available: <https://tigon-project.eu/>
- [91] P.-M. Doitrand, N. Lu, N. Hampton, and K. Zhou, “20 Years of Photovoltaic Cables – what have we learned to prepare for the future?,” presented at the 11 th International Conference on Insulated Power Cables, Lyon, Jun. 2023.
- [92] L.-R. Sales Casals, J. Narbona, G. Moreno, J. L. Pons, S. Colombier, and F. Padillo, “PV SYSTEMS EVOLUTION: CONSIDERATIONS ON PV DC CABLES UNDER INCREASING VOLTAGE AND ENVIRONMENTAL CHALLENGES,” presented at the 11 th International Conference on Insulated Power Cables, Lyon, Jun. 2023.
- [93] Meenakshi Sundaram Ramakrishnan, “Design and Development of LVDC Cables,” Master thesis, Delft University of Technology, 2021.